

Single Walled Carbon Nanotubes as Nanopores for DNA Translocation

Claire McLellan

Physics, Wake Forest University

NNIN REU Site: ASU NanoFab, Arizona State University, Tempe, AZ

NNIN REU Principal Investigator(s): Dr. Stuart Lindsay, Biodesign Institute, Arizona State University

NNIN REU Mentor(s): Dr. Jin He, Biodesign Institute, Arizona State University

Contact: mcleca8@wfu.edu, stuart.lindsay@asu.edu, jinhe@asu.edu

Introduction:

Single molecule deoxyribonucleic acid (DNA) sequencing through nanopores is potentially a fast cost effective way to sequence long strands of DNA. Nanopores have a similar diameter to DNA, so DNA has to unravel itself when it is translocated through the nanopore, about 10 nm for double stranded DNA (dsDNA) and about 2 nm for single stranded DNA (ssDNA). The individual DNA bases can pass the nanopore in a sequential manner [1].

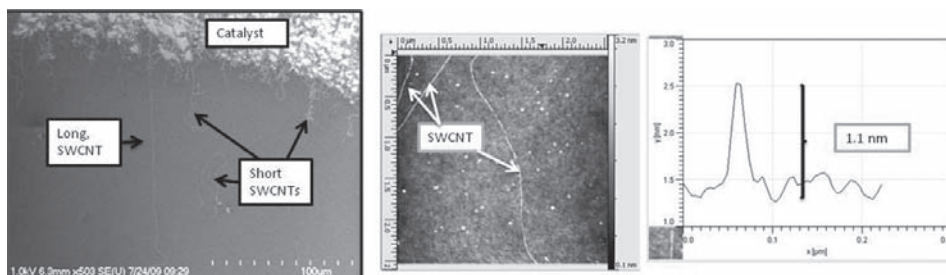

Figure 1: FESEM and AFM with height displacement graph for marker.

To translocate DNA, a voltage is applied across a nanopore that separates two reservoirs of aqueous electrolyte solution. The nanopore essentially becomes a Coulter counter. The ions in the electrolytes move through the nanopore and create an ionic current. DNA, which is a negatively charged molecule, is translocated through the pore by electrophoresis. DNA inside the SWCNT block the ion flow so a change in the ionic current is detected during translocation. Ionic current, as well as tunneling current and optical signal may be used as readout signals for nanopore DNA sequencing. Nanopore sequencing does not include all the complicated and time consuming processes of cloning, polymerase chain reaction, and capillary electrophoresis, potentially sequencing a diploid mammalian genome in 24 hours for about ~\$1000 [2].

Currently nanopores have been created that can discriminate dsDNA and ssDNA by the different pore sizes used for the translocation. Ribonucleic acid (RNA) and DNA are discriminated by differences in the amplitude of the ionic current and the translocation duration time. The length of the DNA is discriminated by a change in the time length when the ionic current is blocked [3].

Single walled carbon nanotubes (SWCNTs) are well structured, long, and natural nanopores with atomically flat inner walls. SWCNTs are about ~ 1-4 nm in diameter and can reach the millimeter scale in length although usually the micron scale. The channel form of the SWCNT provides a

way to contain DNA and potentially control the speed of the DNA when translocated past a base reader. In order to create a SWCNT translocation device, SWCNTs need to be well calibrated.

This summer we investigated SWCNT calibration by growing SWCNTs using a chemical vapor deposition (CVD) method and characterizing SWCNTs using atomic force microscopy (AFM) and field emission scanning electron microscopy (FESEM). We investigated the translocation capabilities of the SWCNTs by measuring the ionic current through the SWCNT based nanofluidic device.

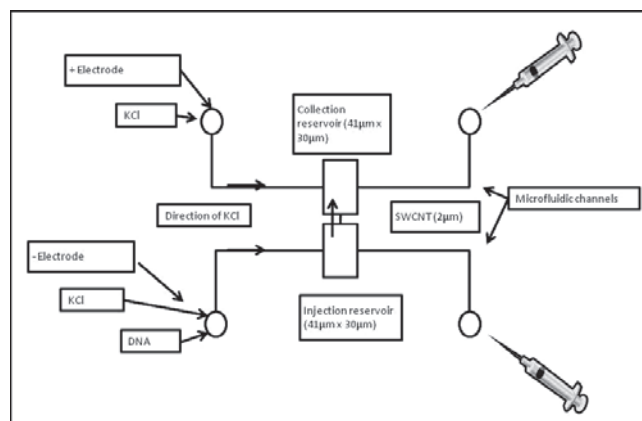

Figure 2: Schematic of DNA translocation device.

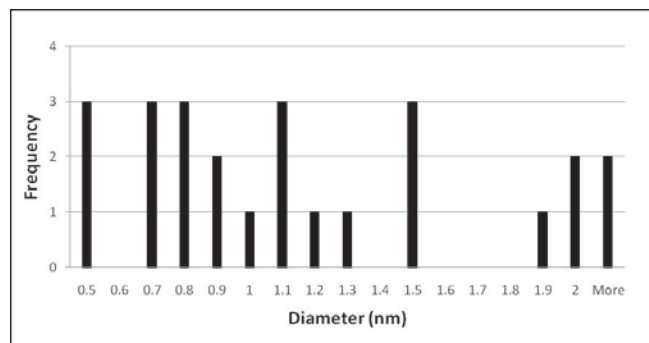

Figure 3: Histogram for SWCNT diameters.

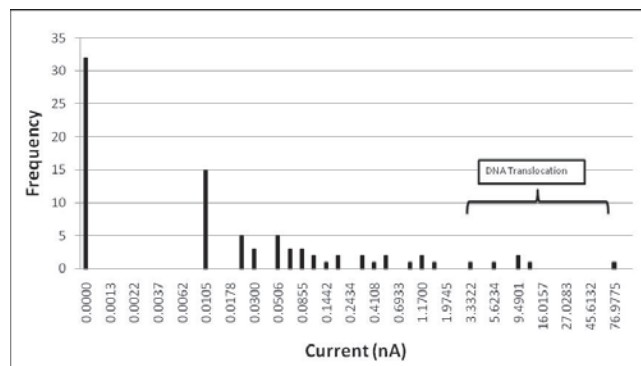

Figure 4: Histogram for SWCNT ionic currents.

Methods and Materials:

The CVD method gives control over SWCNT's orientation, horizontal alignment, length, and diameter. CVD-grown SWCNTs have been shown to have less defects than other methods. The catalyst was produced by a mixture of diblock polymer and cobalt salt. Argon and hydrogen were the gas carriers for the carbon source, ethanol. Ethanol was chosen because the OH group effectively removes any amorphous carbon that would cover and deactivate the cobalt nanoparticles. AFM and FESEM images were used to characterize the grown SWCNTs (Figure 1). A polydimethylsiloxane (PDMS) microfluidic system was prepared and used to introduce solution to SWCNTs. Electron beam lithography (EBL) was used to create reservoirs in the PMMA resist layer that covered on top of the SWCNTs. Oxygen plasma was used to remove the exposed SWCNT in reservoirs and open both ends of the SWCNT that connected two reservoirs. The SWCNT was soaked with an aqueous potassium chloride (KCl) solution. A voltage was applied across the SWCNT for ionic current (Figure 2).

Results and Discussion:

The diameters of the SWCNTs found using AFM are illustrated in Figure 3. The spatial distribution was found using FESEM. The distribution distances were taken 100 μm from the catalyst on four silicon dioxide (SiO_2) substrates. Usually surface density is used when studying distribution, but the SWCNTs were parallel so distances were found. The mean was $111 \mu\text{m} \pm 98 \mu\text{m}$. It was common to find many SWCNTs close to one another and then have hundreds of microns before another SWCNT was found. More SWCNT were found in the area closer to the catalyst. The CVD method of growing SWCNTs was successful in respect to growing many SWCNTs that were long and straight, well dispersed, with usable diameters. If a diameter was too small, the DNA could not translocate and if it was too large, the ionic current change was not obvious. The optimal diameter was 2 nm.

We tested the ionic current of the SWCNTs that had been etched by oxygen plasma and placed in a translocation device; the results are shown in Figure 4. Most, 67%, of the devices made were successful at transferring ionic current. Those devices that did not transfer current could have been contaminated, contained defects, or not opened entirely on each side. The SWCNTs that had successful ionic currents could be used for DNA translocation testing.

DNA translocation favors high ionic current. The distribution of currents may be caused by the distribution in diameter. It would be useful to study how to increase the yield of SWCNTs with high currents. Research in efficient DNA sequencing will help the understanding of the genome and its applications in medical research.

Acknowledgements:

I would like to acknowledge the National Science Foundation and the National Nanotechnology Infrastructure Network Research Experience for Undergraduates (NNIN REU) Program for providing the funding for this internship, Arizona State University for providing the facilities, Trevor Thornton for organizing the program, and Dr. Stuart Lindsay, Dr. Jin He and his graduate students for sharing their knowledge and laboratory.

References:

- [1] Austin, R. (2003). Nanopores: The art of sucking spaghetti. *Nature Materials*, 2, 567-568.
- [2] Branton, D., Deamer, D., Marziali, A., et al. (2008). The potential and challenges of nanopore sequencing. *Nature Biotechnology*, 26(10), 1146-1153.
- [3] Rhee, M. and Burns, M. A. (2006). Nanopore sequencing technology: nanopore preparations. *TRENDS in Biotechnology*, 25(4), 174-181.