

OLED for Lighting

Monica Katiyar
MME & SCDT
Indian Institute of Technology,
Kanpur

Outline

- Lighting
- Photometry and colorimetry
- Some examples
- Various approaches to W-OLED

Lighting

500,000 years ago

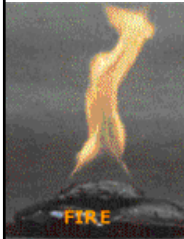

Gas lighting 1772



Electric bulb 1876
Fluorescent lamp 1938

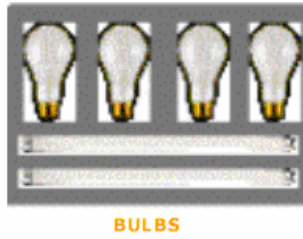

~2000

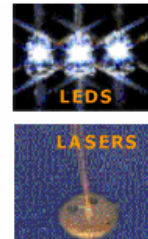

“The vision of Solid-State Lighting is to complete the evolution of lighting from primitive fire-based technologies like candles and lanterns, to vacuum-tube and bulb based technologies like incandescent and fluorescent bulbs, and finally to semiconductor-based technologies like LEDs and lasers. “

From: lighting.sandia.gov

US power consumption on lighting - 20%

2001 Estimate: 7.2 quads

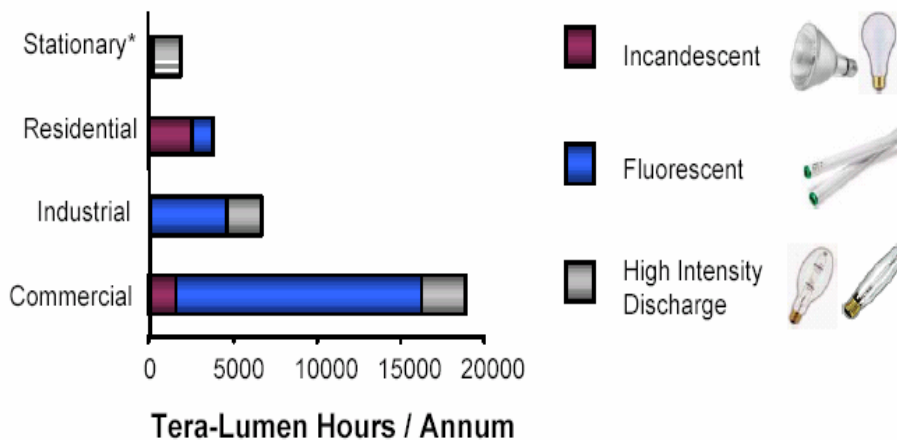

Energy savings potential of solid state lighting in general lighting applications, DOE report, 2001

Terminology

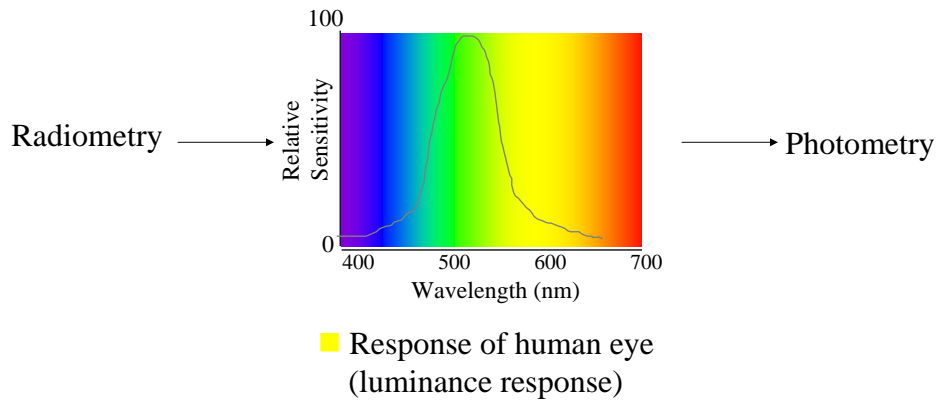

Radiometry

1. Radiant Flux: total radiant power (**W**)
2. Radiant Intensity: radiant flux through a cone of one steradian (**W/sr**)

Photometry

1. Luminous Flux: power useful to eye; at 555nm 1W radiant flux corresponds to 683 (**lm**)
- *Luminous efficacy: lm/W, theoretical maximum 683*
2. Luminous Intensity: luminous flux through a cone of one steradian (**lm/sr = Cd**)

<u>Radiometry</u>	<u>Photometry</u>
3. Irradiance: optical radiation falling upon a specified area (W/m^2)	3. Illuminance: visible light falling upon a specified area ($lm/m^2=lx$)
4. Radiant Exitance: optical radiation emitted/reflected/transmitted by m^2 of surface (W/m^2)	4. Luminous Exitance: visible light emitted/reflected/transmitted by m^2 of surface (lm/m^2)
5. Radiance: light emitted/reflected/transmitted by diffusing surface ($W/sr/m^2$)	5. Luminance: visible light emitted/reflected/transmitted by diffusing surface ($lm/sr/m^2=Cd/m^2$) <i>- equivalent to subjective quantity "Brightness"</i>

A light source 100 lm of luminous flux,
but is it or is it **green**?

Colorimetry

- Primary colours: R, Y, B or R, G, B?
- CIE colour coordinates

CIE Standard

- CIE: International Commission on Illumination (Commission Internationale de l'Eclairage).
- Human perception based standard (1931), established with color matching experiment.
- Standard observer: a composite of a group of 15 to 20 people

Chromaticity Diagram

- Colour expressed as 2-D plane by projecting tristimulus values ($x + y + z = 1$)
- Chromaticity coordinates (x, y) define colour

$$x = \frac{X}{X + Y + Z}$$

$$y = \frac{Y}{X + Y + Z}$$

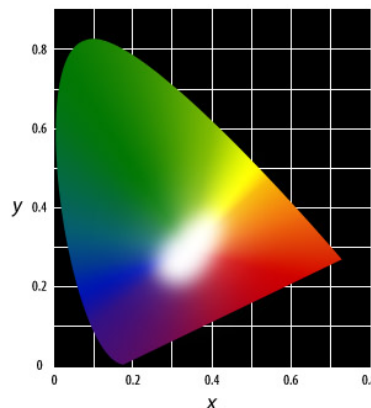

The co-ordinates of white point in Commission Internationale de l'Eclairage (CIE) system 1931 is defined as (0.33, 0.33).

Colour Temperature

- A body heated above 800K will produce broad emission spectrum with its colour related to temperature.
- Increasing temperature changes colour from red to orange, yellow, white and bluish white (called the Planckian locus).
- Sun, stars, fire produce light on this locus. So goal of man made light sources is also to make light sources lie on this locus.
- Incandescent lamp (2854K), warm-white fluorescent lamp (3000K), day light fluorescent lamp (6500K) all fall on the locus.
- Those that don't: sodium and mercury lamps, *with high efficiencies but with unnatural appearance* (Correlated Colour Temperature)

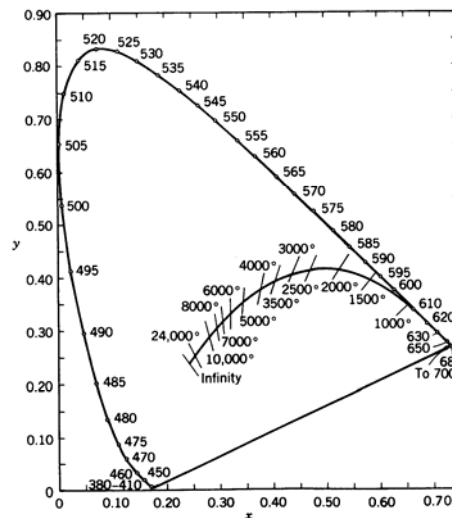

Figure 1.16. Planckian locus plotted on 1931 CIE Chromaticity Diagram. Temperatures are shown in Kelvin. (From Navships Display Illumination Guide, p. 1-13, 1973.)

Colour Rendering Index

- Color Rendering Index (CRI) of a light source is the measure of how true the colors of an object look when illuminated by that light source. It is measured in 0-100 scale, with 100 being the highest ability for color rendering.

Status of solid state lighting(SSL)

Lighting Sources	Efficacy (lumens/Watt)	Color Rendering Index	Lamp Life (1000 hrs)	Lamp Price (\$/klm)
Incandescent	16	95	1	0.4
Tube Fluorescent	85	75	10	1.5
White -LEDs (III-V semiconductor based)	25	75	20	200
White -OLEDs	46	80	5	?

Adapted from :
 Organic Light Emitting Diodes for General Illumination, *Report prepared by Optoelectronics Industry Development Association and Department of Energy*
 – Office of Building Technology, State and Community Programs

Promise of Solid State lighting

- Reduction of energy consumption
- Positively affect the greenhouse effect by reducing the emission of CO₂
- Create new industry and new jobs.

New Applications

OLEDs will eventually displace area (distributed) sources such as fluorescent lamps, but in many applications also incandescent lamps.

OLEDs will also create new lighting possibilities by enabling large area illumination sources, panels, ceilings, walls, partitions, fabrics etc.

Lumileds

- Lumileds, a joint venture between Philips Lighting and Agilent Technologies, is the world's leading manufacturer of high-power inorganic coloured and white LEDs, and a pioneer in the use of solid-state lighting solutions for everyday purposes, including automotive lighting, traffic signalling, signage, LCD backlighting and general lighting.
- From: www.research.philips.com

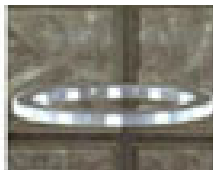

Inorganic vs. Organic SSL

- Shift from inorganic to organic LEDs for this application:
 - ease of production
 - low cost,
 - low operating voltages,
 - wide viewing angles,
 - tunability of the color emission,
 - fast response time,
 - compatibility to flexible substrates
 - and ease of forming large area.
- Luminance and efficiency have been continuously improving

WOLED SSL

- General Electric's White OLED using a down conversion phosphor system and a blue OLED.
- From: oemagazine.com.

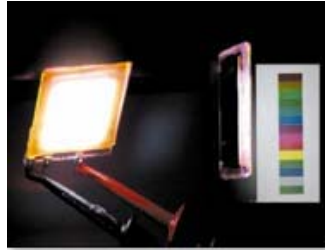

March 2008

Osram's polymer LED 46 lm/W

Brightness ~ 1000 Cd/m²

Life time 5000 hrs

How to generate WOLED?

- White light is made up of nearly equal intensities of light from all regions (VIBGYOR) of the visible spectrum.
 - Combining three different wavelengths of light - 'primary colors'.
 - 'complementary colors' where the combination of only two colors can produce white light.

Organic molecules generally have very broad emission spectra, therefore, combination of emission from not exactly complementary colors may also give white light.

Various Approaches to obtain white light

- Host-guest system
- Multilayer structure
- Exciplex emission
- Microcavity
- Down conversion phosphorous
- Single Molecule

Host-guest System

- Single/multiple dopants
- Full/partial energy transfer
- Fluorescent/phosphorescent dopants
- Colour tunability
 - Dopant concentration
 - Dependent on energy transfer rates
 - Change in colour with current densities

Host-Guest Cont..

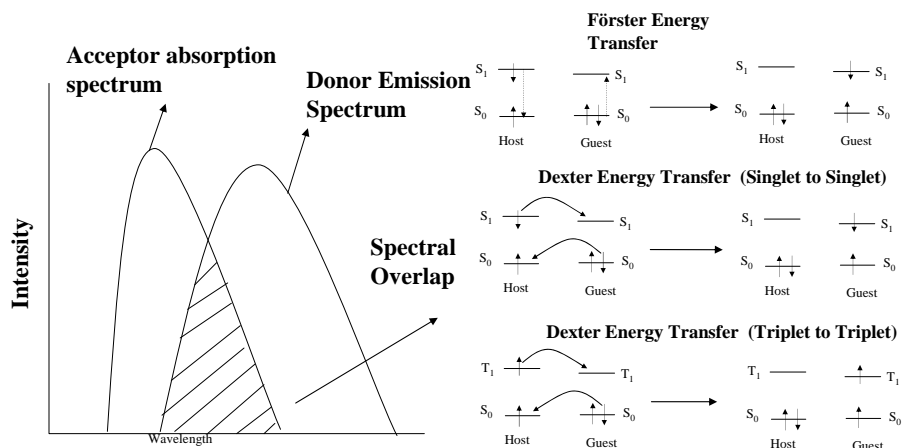

Multilayer structures

- Mixing of the emission from different layers
- Spectral characteristic by adjusting the recombination-zone
- Excitons are also allowed to diffuse between two layers

Multilayer structures cont.

- Emission depends on layer thickness and voltage
 - electron-hole mobility and exciton diffusion length
- Solution: put carrier and exciton barriers for different layers
 - Improves efficiency as well
- Drawback-processing difficulty

Photolumuminescence quenching of Alq₃ by metal deposition: A surface analytical investigation

V.-E. Choong, Y. Park, and Y. Gao^{a)}
Department of Physics and Astronomy, University of Rochester, Rochester, New York 14627

M. G. Mason and C. W. Tang
Imaging Research and Advanced Development, Eastman Kodak Co., Rochester, New York 14650

(Received 28 October 1997; accepted 23 February 1998)

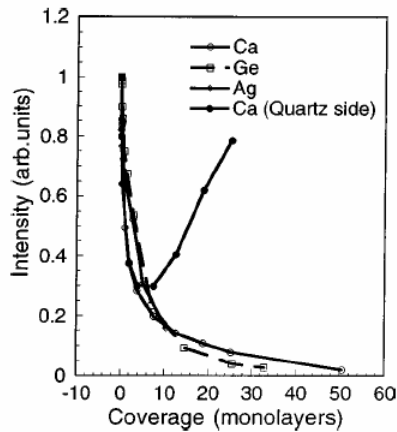

Alq₃ ~300 Å
 70% quenching

$L_D \sim 210 \text{ \AA}$

July 14, 2007

Current Balance

is made more difficult because of large difference in carrier mobility

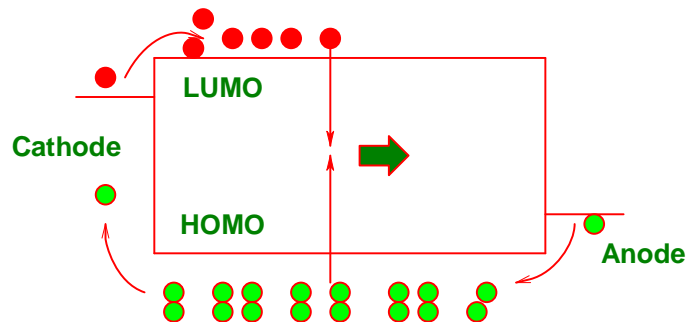

Alq₃ : $\mu_{po} = 1.9 \times 10^{-6} \text{ cm}^2 / \text{Vs}$; $\mu_{no} = 1.9 \times 10^{-8} \text{ cm}^2 / \text{Vs}$

July 14, 2007

Carrier Profile in Single Layer OLED with widely differing electron and hole mobilities

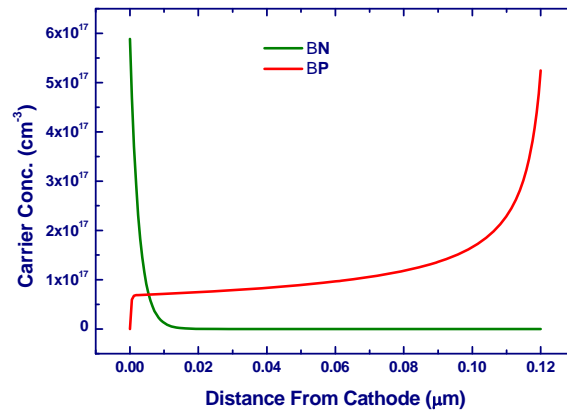

July 14, 2007

Recombination Profile

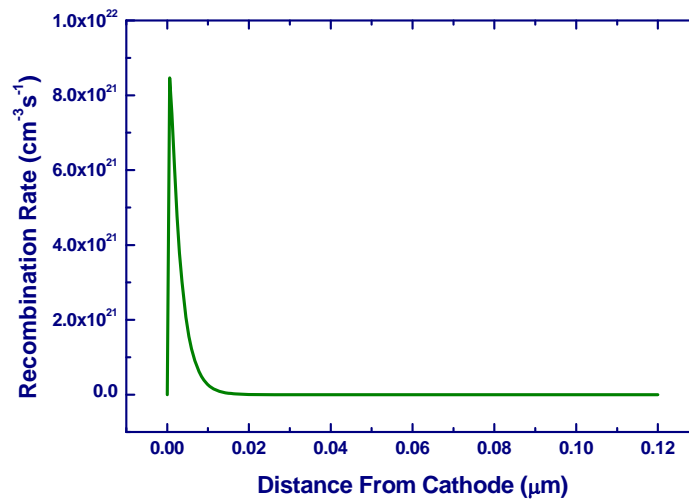

July 14, 2007

- large fraction of holes are simply collected at the Cathode.
- Most of recombination takes place close to Cathode where probability of non-radiative recombination is high.
- Key Problem:
 - How do we balance electron and hole currents?

July 14, 2007

- Use two different organic materials with properties such that electron flow to Anode and hole flow to cathode is blocked.

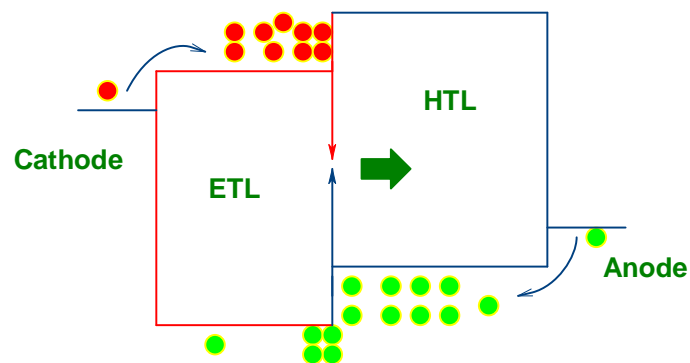

July 14, 2007

Carrier Profile in Bilayer OLED

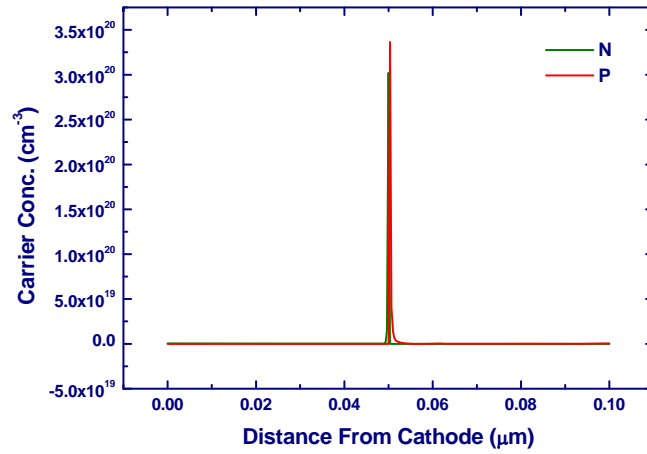

July 14, 2007

Recombination Profile in Bilayer OLED

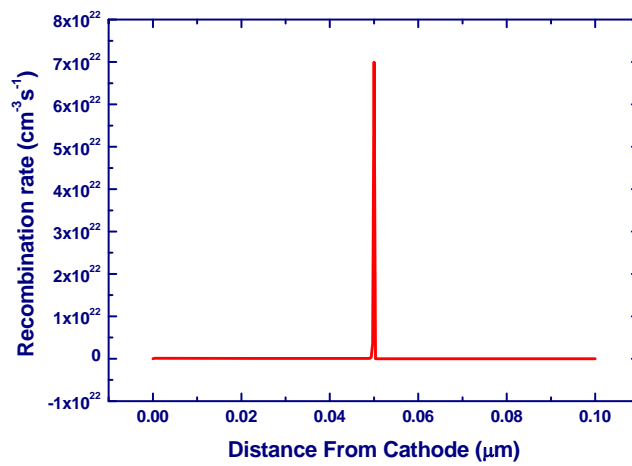

July 14, 2007

- 1987, C.W. Tang and S.A. VanSlyke from Eastman Kodak Company reported an OLED based on the above principle

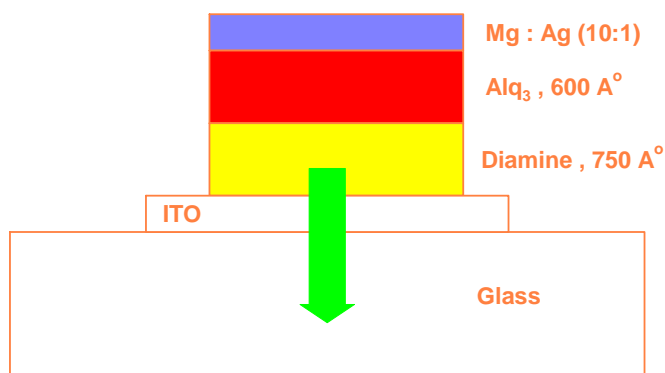

July 14, 2007

Exciplex/Excimer Emission

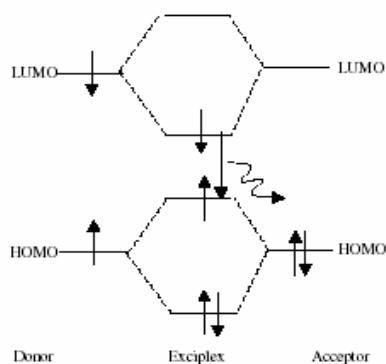

- Two blue emitting molecules with sufficient spatial overlap in a blend

-depends on concentration, structure and morphology of the film

- Exciplex formation at the interface
 - Large difference in the HOMO/LUMO levels is preferred

- Emission colour dependent on thickness of the layer and applied electric field

Drawback: Temperature dependence of the emission

Microcavity

- Concept of Fabry-perot resonant cavity

- Draw back : angular dependence of emission

Down conversion phosphors with OLEDs

- Popular technique in inorganic semiconductors

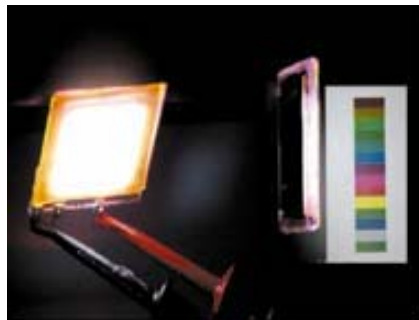

UV-OLED : Polysilane - series

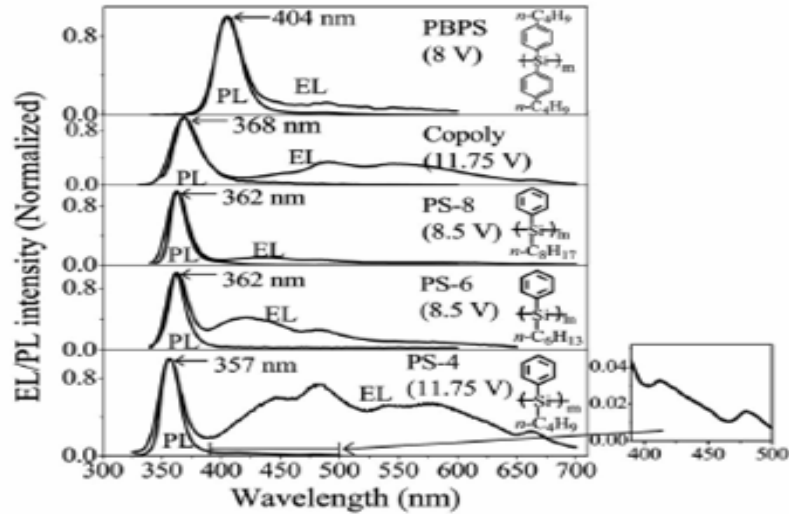

J. Appl. Phys. 102, 084506, (2007).

White emission from single molecule

- Material should have chromophores for all regions
 - PL shows blue emission
 - EL has all components
 - Intra/inter molecular charge transfer complexes
 - aggregates
- Drawbacks
 - Voltage dependent emission
 - Solvent and morphology dependence

References

- Dipti Gupta. M. Katiyar, Deepak, Optical Materials (available online)
- Energy savings potential of solid state lighting in general lighting applications, DOE report, 2001
- Organic Light Emitting Diodes for General Illumination, *Report prepared by Optoelectronics Industry Development Association and Department of Energy – Office of Building Technology, State and Community Programs*