

Catalyzing Progress in Nanotechnology

NATIONAL NANOTECHNOLOGY INFRASTRUCTURE NETWORK



Catalyzing Progress with Nanotechnology

As children, we all marveled at how we humans had transformed the world around us using technology. We could fly; we took a round trip to the moon; we saw the obsolescence of the slide rule for calculations; our hearts could be replaced, and science had created the agricultural revolution. All this became possible because of discoveries and inventions by scientists, engineers, doctors and medical researchers, inventors of all kinds. All this would have been impossible without a society that encouraged and put resources into the enterprises that educate and support the entrepreneurship of learning, discovery, and application.



Sandip Tiwari, NNIN Director

What are today's fascinating and challenging problems whose solutions can help our world? Energy, better health, equity, education, and conservation all immediately come to mind. Can we lower energy consumption — for transportation, for lighting, for computing and all the mobile instruments we use? Can we help with water problems — get clean water, remove heavy metal impurities such as arsenic, and reduce water use? Can we improve on agricultural productivity — plants for healthier diets, more disease resistant plants, crops that consume less energy and water? Can we improve on the use of forestry resources — more efficiency, less use of paper and better paper production techniques? Can we improve on health care — diagnose more cheaply and earlier, detect contamination, cure diseases, improve treatment or slow the progress of degenerative diseases? Can we attack the most pernicious of the diseases — malaria and cancer? There is a long list of such challenges that are central to our human existence. The answers that science can provide could become a major social force.

Can we find the answers to these questions, which all affect our quality of life and our equilibrium with nature? Most definitely yes. We will need ideas, will-power, serendipity, and above all a tremendous effort on the part of scientists and engineers and the broader community. How can we be so sure? What is the common theme in finding the answers? The necessary efficiency and control happen through atomic, molecular or interface processes whether in the physical world or in the life science world. ***This is nanotechnology.*** We now have an ever increasing set of tools that allow us to assemble, manipulate, control, and probe at this level. We can synthesize atom by atom and we can also sculpt to get down to near the atomic level. We can "see" the phenomena that happen at this scale through a large set of tools that give us a variety of views. And because the properties change dramatically when we get down to the smallest units, we can leverage those properties by utilizing our assembly and

Catalyzing Progress with Nanotechnology

sculpting techniques. So fuel cells and better batteries become possible through control of electrochemical reactions at interfaces, transport in thin membranes, and superior catalyzing approaches. We can make major improvements in power consumption because we can make electronic devices much less power hungry, make long lasting light emitting diodes that can replace inefficient tungsten lamps, make solar cells that start to take advantage of the unusual charge separation properties of interfaces, perhaps even improve on photosynthesis for energy conversion. We can purify water through significant improvements in the interface-mediated purification processes, we can increasingly replace paper by storing and viewing information in electronic media, and the list goes on. Newspaper consumption is already decreasing because of the web, and neural probes have been employed to deliver drugs and make connections that have dramatically altered the impact of neurological diseases. There are now numerous diagnostics that employ very small specimens to detect, e.g., E Coli, and small artificial organ models can be built to analyze interactions in human organs. Electronics and communications continue to make tremendous progress through the use of nanoscale devices and techniques.

If we speculate within reasonable bounds, what might be possible tomorrow? I suspect that improvements of an order of magnitude should be possible in energy consumption, such as in lighting or computing, and in energy generation, such as in photovoltaics or batteries. Clean fuel cells should allow us to build large enough units to be useful in many transportation applications. The day when somebody assembles an artificial biological cell is not far off. And with what we know now from our use of nanotechnology approaches in the life science world, there is every reason to believe that a similar impact can be achieved in the agricultural world.

What will be needed to accomplish this? Bright people – scientists, engineers and inventors, an educated workforce, a sharing of knowledge across the breadth of disciplines, access to the instruments that make practice possible, and a committed cooperative effort. The National Nanotechnology Infrastructure Network (NNIN) is a National Science Foundation funded network of university-based laboratories that provide the open, interdisciplinary, hands-on environment for scientists and engineers, discoverers and inventors and students, that enables them to come together and use the simple and complex instruments of nanotechnology to bring their ideas to fruition.

The open environment of our facilities, an experiment that started in 1979, has a remarkable record. Many of the major breakthroughs of the past two decades that have led to the current public attention to nanotechnology have come from our laboratories. The first experiments in genetic modification, by direct implantation into cells, were conducted here. The first studies of the effects of physical surface structures on fungus and cellular growth were

conducted in our laboratories. The first laboratory-a-on-chip and microenvironments for testing and analyzing reactions in organ models were created here. The earliest neural probes and delivery systems came from our laboratories. We have made the smallest transistors and memories and introduced new technologies such as three-dimensional integration in computing, and seeded new discoveries in organic structures for flexible electronics. New soft lithography and self-assembly techniques have been introduced by our users. Scientific discoveries and tours-de-force that we have contributed to include the demonstration of spin-torque effect, the measurement of single spin from dopants in silicon, and a large variety of quantum phenomena that can only be observed at the atomic scale. The more than 1200 Ph.D.s awarded every year and the nearly 700 industrial users from more than 250 companies leverage this open environment.

Science and engineering have bigger roles to play in this world as all countries progress and continue to improve their citizens' lives. We will have to do this while respecting nature, nature's seniority, and the interconnectedness and impact of what we do. Welcome to this journey and I invite you to contribute to it.

— Sandip Tiwari



Nanotechnology: Engine of 21st Century Progress

What is nanotechnology?

Nanotechnology is the understanding and control of matter at dimensions of roughly 1 to 100 nanometers, where unique phenomena enable novel applications. Encompassing nanoscale science, engineering and technology, nanotechnology involves imaging, measuring, modeling, and manipulating matter at this length scale.

— www.nni.gov

Nanotechnology has emerged in the last decade as a driving force for both technology evolution and technology revolution. Both government and corporate investment are fueling this wave of nanotechnology development, both within the U.S. and across the globe.

With the creation of the National Nanotechnology Initiative (NNI) in 2000, in recognition of the enormous potential of this technology, the U.S. federal government established a mechanism for coordinating the government's investment and promoting the growth of nanotechnology. As a result, there are now significant nanotechnology research programs in 23 federal agencies, addressing defense, energy, domestic security, health, environment, and transportation, to name a few. Many states have similarly established nanotechnology initiatives in recognition of the enormous economic development potential presented by nanotechnology commercialization. Simultaneously, foreign governments of most technological countries have established large research, development, and commercialization programs in nanotechnology. Spurred by this enormous government investment, industries and academia alike, in both the US and abroad, have embraced nanotechnology as the driver of the next economic and technological revolution.

Many of the concepts of nanotechnology are not new. Scientists have known for years that small particles can have unique properties, for example, the ability to catalyze particular chemical reactions. Similarly, for many years the effects of quantum confinement have been readily apparent in a variety of electronic and optical phenomena. And from the systems and devices end, microelectronics has been pushing the limits of complex patterned fabrication for 40 years, most recently reaching into the "nano" domain in both lithography and materials engineering. What is critical about the nanotechnology revolution, however, is that now, due to the invention of new tools and processes, scientists and engineers can both understand and control the fabrication and synthesis of materials and structures at the nanometer scale, making it into a true engineering endeavor.

Tools such as the scanning tunneling microscope and the atomic force microscope have been critical to the growth of this field. Similarly, the discovery of C_{60} and nanotubes spawned investigation of entirely new classes of nanometer-scale engineered materials, not only in carbon but other materials as well. The recent Nobel Prize in Physics for the discovery and application of the Giant Magneto Resistance effect also recognizes a significant achievement in materials engineering at the nanoscale.

Nanotechnology: Engine of 21st Century Progress



The impact of nanotechnology on society in the next 30 years will be enormous and will permeate society. The unique properties of nanostructured materials and systems are already used for a variety of consumer products including tennis rackets and baseball bats and more advanced technology devices including hard disks, flash memory, sensors and actuators, etc. Applications are rapidly developing for drug delivery, disease diagnosis and treatment, water purification, pollution control, advanced structural materials, solid state lighting, communications, and even more advanced electronic and photonic devices.

While there is considerable commercial development of near-term products employing nanotechnology, government agencies and universities have a primary role to play in the research and development of novel, longer term nanotechnology devices and concepts. Both patents and publications within the nanotechnology space are growing, seemingly without bound. The enormous increase in funding directed to nanotechnology research is bringing a constant stream of new researchers, in academia, government, and industry into the field of nanotechnology. The availability of

infrastructure to support this growing interest is a critical gating parameter.

NNIN is a premier resource for enabling nanotechnology research and development, particularly within the academic and small business communities. And it is not a newcomer to this area. While the term nanotechnology has become common only within the last 10 years and the term has developed a new and broader context during that period, some of the facilities within NNIN have been enabling nanotechnology for 30 years. The enormous growth of interest in nanotechnology in recent years has made NNIN an even more important part of the national research infrastructure.

Nanotechnology: Engine of 21st Century Progress

The NNI Investment Strategy

At the national level, the National Nanotechnology Initiative has a well-defined investment strategy, both building upon current programs and initiating new efforts. NNIN, as part of the overall NNI strategy, fits squarely within this framework, as a direct, major participant in the first four of the following thrusts.

- Long-term fundamental nanoscience and engineering research that will build upon a fundamental understanding and synthesis of nanometer-size building blocks with potential breakthroughs in areas such as materials and manufacturing, nanoelectronics, medicine and healthcare, environment and energy, chemical and pharmaceutical industries, biotechnology and agriculture, computation and information technology, and national security.
- Centers and Networks of Excellence that will encourage research networking and shared academic users' facilities. These nanotechnology research centers will play an important role in development and utilization of specific tools and in promoting partnerships in the coming years.
- Research Infrastructures will be funded for metrology, instrumentation, modeling and simulation, and user facilities. The goal is to develop a flexible enabling infrastructure so that new discoveries and innovations can be rapidly commercialized by U.S. industry.
- Ethical, Legal, Societal Implications, and Workforce Education and Training efforts will be undertaken to promote a new generation of skilled workers in the multidisciplinary perspectives necessary for rapid progress in nanotechnology. The impact that nanotechnology has on society from legal, ethical, social, economic, and workforce preparation perspectives will be studied. The research will help us identify potential problems and teach us how to intervene efficiently in the future on measures that may need to be taken.
- Grand Challenges as outlined at right.

Source: National Nanotechnology Initiative publications

Grand Challenges of the National Nanotechnology Initiative

As benchmarks to drive and measure progress, NNI has established seven long-term Grand Challenges for Nanotechnology. Most important about these challenges is that they highlight the diverse impact expected throughout society from this effort over the next 10, 20 or 30 years.

- Shrinking the entire contents of the Library of Congress in a device the size of a sugar cube through the expansion of mass-storage electronics to multi-terabit memory capacity that will increase the memory storage per unit surface a thousand fold;
- Making materials and products from the bottom-up, that is, by building them up from atoms and molecules. Bottom-up manufacturing should require less material and pollute less;
- Developing materials that are 10 times stronger than steel but a fraction of the weight for making all kinds of land, sea, air, and space vehicles lighter and more fuel efficient;
- Improving the computer speed and efficiency of miniscule transistors and memory chips by factors of millions, making today's processors seem slow;
- Using gene and drug delivery to detect cancerous cells by nanoengineered MRI contrast agents or target organs in the human body;
- Removing the finest contaminants from water and air to promote a cleaner environment and potable water;
- Doubling the energy efficiency of solar cells.



The National Nanotechnology Infrastructure Network

The National Nanotechnology Infrastructure Network (NNIN) exists to facilitate all aspects of nanotechnology research by providing access on an open basis to advanced nanotechnology instrumentation, processes, and training. These resources are provided through a supportive network of 12 leading academic nanotechnology laboratories.

NNIN was formed in March 2003 as a result of an open nationwide competition conducted by the National Science Foundation. The winning team, lead by Cornell and Stanford universities, was awarded a five-year contract worth \$14 million per year. This award will be up for renewal in 2009. Prior to 2003, five of the current NNIN sites comprised NNUN, the National Nanotechnology Users Network, the predecessor of NNIN. The network continues in the tradition established by NNUN but with a broader base of institutions while embracing the broader scope of nanotechnology that has evolved in the last decade.

Central to the operation of NNIN is the commitment to provide open access to advanced technology for the entire nanotechnology community. With the rapid growth and unlimited potential of nanotechnology, it is critical that the nation provide appropriate accessible research resources. Through NNIN everyone can have access to state-of-the-art nanotechnology resources. This is in stark contrast to most academic and industrial laboratories that are closed to all but their owners.

To meet the challenge of providing broad access to state-of-the-art technologies, NNIN has highly developed education and training protocols and activities, playing a significant role within the national community.

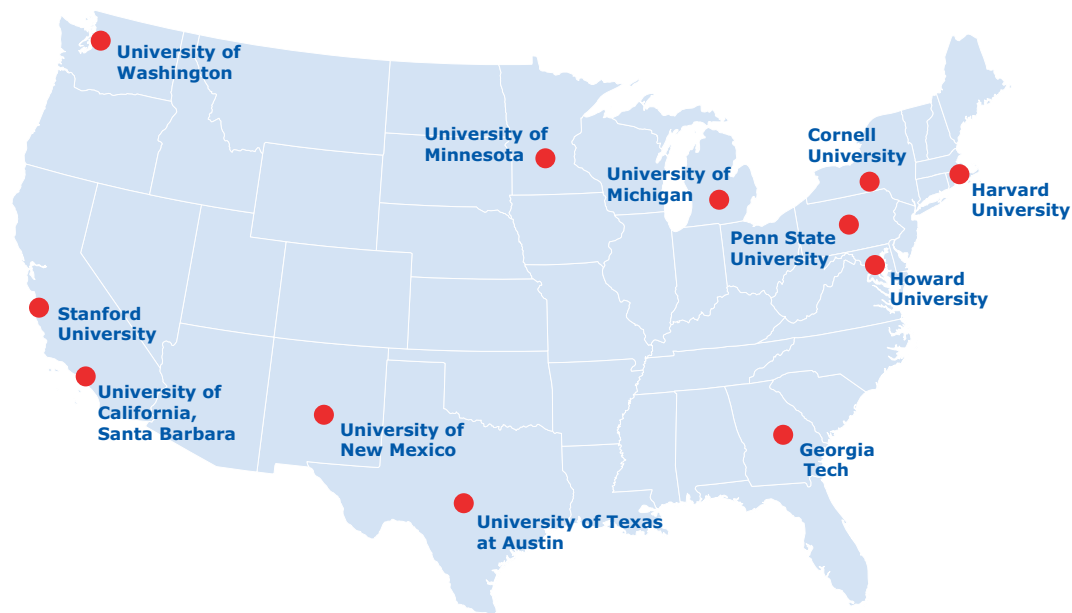

The National Nanotechnology Infrastructure Network



In order to assure that the network remains dynamic in its support and capabilities and makes judicious use of resources, the network sites have assigned technical focus areas for leadership. These areas correspond to the areas of exceptional strength of the local research and allow us to selectively apply precious financial resources towards maintaining the most advanced capabilities for the national community. Cornell and Stanford provide extensive support across disciplines as well as for complex integration projects. For biology and life-sciences, Georgia Tech and the University of Washington; for chemistry at the nanoscale, Pennsylvania State, Harvard University and University of Texas; for geosciences, the universities of New Mexico and Minnesota;

for integrated systems, University of Michigan; for tool development and manufacturing research support, University of Texas; for remote use and characterization, the universities of Minnesota and New Mexico provide the focus technical area leadership.

The sites of NNIN provide both geographical and technological diversity. Users are free to use any of the NNIN sites or even multiple sites. The availability of the desired technology is often the driving force in site selection. While there is some geographic localization of users around the NNIN facilities, users often travel across the country to get access to the best technology.

The National Nanotechnology Infrastructure Network

NNIN Sites

- Cornell Nanoscale Science and Technology Facility
- Stanford Nanofabrication Facility
- Microelectronics Research Center (MiRC) at Georgia Institute of Technology
- Michigan Nanofabrication Facility at the University of Michigan
- Center for Nanotechnology at the University of Washington
- Penn State Nanofabrication Facility
- Nanotech at the University of California Santa Barbara
- Microelectronics Research Center (MRC) at the University of Texas at Austin
- Nanotech at the University of New Mexico
- MINTEC at the University of Minnesota
- Center for Nanoscale Systems at Harvard University
- Howard Nanoscale Science and Engineering Facility at Howard University



NNIN Program Philosophy

In assembling the network, NNIN focused on selecting sites with exceptional technical strengths underpinned by strong local research programs, a commitment to the principles of openness and flexibility, strong internal support, capacity for growth to address emerging needs, and geographical diversity. Each of the NNIN sites has expertise in at least one, and typically several, of the critical nanotechnology areas.

The NNIN principles to which each site in the network has agreed are:

- Open and equal access to all projects independent of external or internal origin
- Single-minded commitment to service of users with a special focus on external users
- Commitment to support interdisciplinary research and the needs of users from emerging areas
- Facility ownership and management, not individual faculty ownership, of instruments and other resources
- Openness to new materials, new techniques, new processes, and new applications
- Commitment to maintain high equipment uptime and availability
- Commitment to provide comprehensive training and staff support for efficient research project execution
- Facility governance independent of interference from other local organizations
- Commitment to removal of intellectual-property barriers, in order to provide rapid and efficient access and support to users

With these proven guiding principles, users can expect a common level of support and commitment across the network.

Pipette Disposal

Must be EMPTIED before disposal
Do not use for disposal of hazardous waste



NO SOLVENT
or RESIST on SPINNER
CHUCKS
Clean by WIPING only.
Check must be **SMALLER**
than substrate.



ALARM
BLIND

PHOTORESIST ONLY

NO
ink
or
any
other
soluble
IS THE SPINNER



NNIN Core Competencies

Nanotechnology touches all the major areas of science and engineering. Not that all these areas require the same nanotechnology tools and processes, but they are all impacted by the ability to design and control structures as the nanometer level.

To meet the needs of the diverse nanoscale community, NNIN must have and effectively deliver state-of-the-art technologies across a broad spectrum of applications. This includes the ability to process a variety of non-standard materials and to support users who are new and not yet experts in nanotechnology. This is one of the driving forces for the multi-site network concept embraced by NNIN; no one site can reasonably address all the facets of nanotechnology with equipment and resident expertise, but with a multitude of laboratories, NNIN can draw on the expertise of faculty, staff, and facilities to provide the necessary spectrum of support.

With more than 125 staff (full-time equivalents) and more than \$300M in equipment, NNIN is well suited to provide support to the national nanotechnology research effort. Our core capabilities include:

- Advanced lithography
- Advanced thin film processing
- Advanced materials characterization
- Computation of nanoscale physical and chemical properties.
- Fabrication and synthesis of nanoparticles and nanomaterials
- Biological and chemical processing
- Extensive technical support

Technical Support

While the availability of advanced equipment is often thought of as the limiting resource, NNIN experience has shown that expert staff support is equally necessary, particularly as nanotechnology reaches into new communities and technical areas. At the operational level, NNIN provides this support through its regular technical staff members who work closely with all users to provide instructional and process support. At a higher academic level, support is provided through our technical liaisons or domain experts. These staff members, who typically hold Ph.D.s, are a topical resource for users in particular areas and are experts in relating the capabilities of NNIN and nanotechnology in general to new users. They provide a critical bridge to users from new technical areas and users with advanced technical problems.

Through its combined strengths in equipment, instructional and process support staff, and technical liaisons, NNIN provides a unique and powerful resource to support nanotechnology research.

NNIN Core Competencies



Advanced Lithography

The ability to make complex patterns of materials at microscopic dimensions is a critical part of fabricating many functional nanostructures. This process is called lithography. NNIN facilities are well equipped for all forms of this critical technology. Photolithography, electron-beam lithography, nanoimprint, and focused ion-beam fabrication comprise the core of NNIN's lithographic capabilities. Multiple state-of-the-art tools give the network the capabilities and capacity to meet the needs of most users.



Advanced Thin Film Processing

Thin film deposition and etching are critical to nanofabrication. These include deposition and growth of metals, insulators, and semiconductors as well as removal of these films through wet or dry etching. The situation is complicated by the broad range of materials encompassed within the new nanotechnology. Materials requirements extend far outside the historic range of silicon-compatible materials. NNIN has broad processing capability for standard and novel materials.



Advanced Materials Characterization

Characterization at the nanoscale is an inseparable part of fabrication of nanoscale structures. Obviously, one needs to see the micro- and nanoscale features that have been made. Also, however, one needs to be able to measure the physical, mechanical, and electrical properties of materials at the nanoscale. While several sites specialize in characterization, all sites have a suite of advanced characterization tools. These include advanced electron beam and scanned probe instruments as well as a variety of optical, mechanical, and electrical characterization instruments.

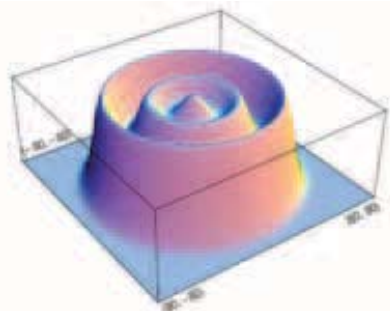

Computation of Nanoscale Physical and Chemical Properties

Simulation of complex nanoscale phenomena is an important tool for understanding experiments. The Harvard and Cornell sites of NNIN maintain extensive computation resources to support the modeling of nanoscale phenomena. These include codes to approach problems from both the computational chemistry and computational physics angles.

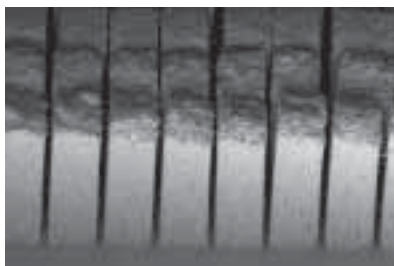

Fabrication and Synthesis of Nanoparticles and Nanomaterials

Nanostructured materials and nanosized materials (nanotubes, quantum dots, etc.) are increasingly important in enabling advances in nanotechnology. These materials may be part of active electronic devices, used for structural materials or coatings, or used as an active component in a variety of novel chemical reactions. NNIN has a variety of facilities available to support the growth, fabrication, or synthesis of nanoscale materials.



Biological and Chemical Processing

The most rapidly growing facets of nanotechnology, at least within NNIN, are the applications to biology and chemistry. This is an extremely broad area that encompasses patterning of biological materials as well as the development of bio and chemical sensors, often using MEMS, microfluidics, photonics, or electronic technology, integrated with specific biochemical functionality. Because the materials needed for biocompatibility are often different than materials used for electronics and optics applications, a much broader set of instruments is required. NNIN is well suited to support this growing area of nanotechnology.

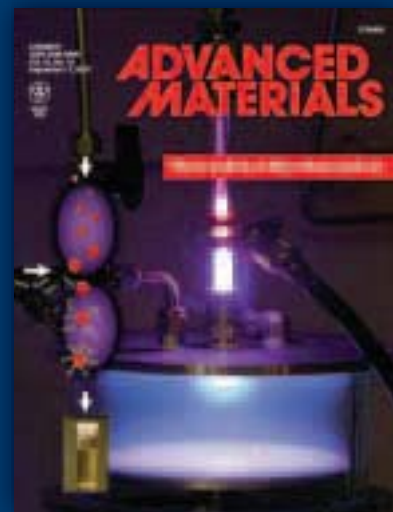
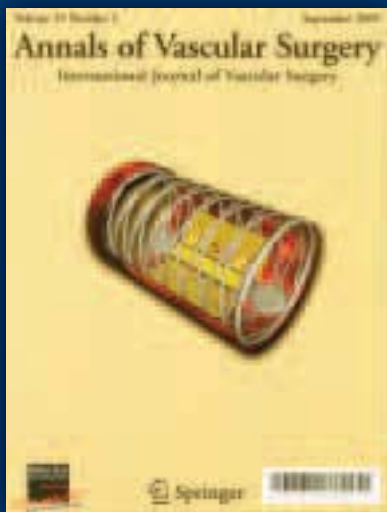
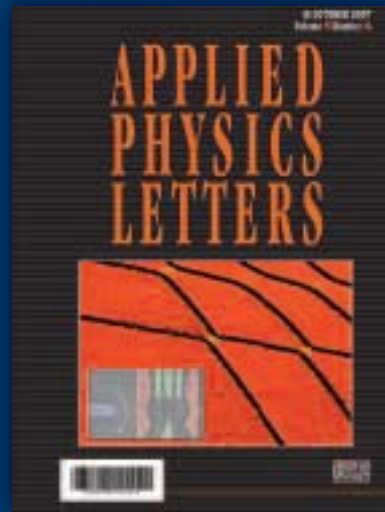

NNIN Research Impact

NNIN provides significant leverage in support of the national research agenda. Supported by only 125 full-time-equivalent staff, each year more than 4,400 researchers depend on NNIN for at least part of their research and development activity. Through its shared resources, the \$14 million direct government investment, NNIN enables more than \$500 million research annually.

The research impact of NNIN extends across the fields of nanotechnology.

In 2007, more than 3,000 journal publications and conference presentations resulted from NNIN activity. Some of the more notable accomplishments have been featured on the covers of major journals and trade publications. Some of these are highlighted in this report.

Access to NNIN Facilities and Resources

NNIN is a research-enabling resource for academic, industrial and government organizations across the country. While our expertise is leveraged heavily upon the research expertise at our universities, we are fundamentally different than a “research center” in that we have no pre-defined research agenda — our users determine what research is done within the NNIN facilities. Neither is access built upon collaboration. While users are welcome to collaborate with NNIN staff or associated faculty, most users want access to equipment without additional intellectual strings. Outside users have access to all the same NNIN facilities as local faculty and students.

NNIN facilities are set up as user facilities, with extensive support from experienced technical staff. Access is on an equal and open basis; only a brief research description is required. Instrument training and project support are available as needed. Most projects can begin within a few weeks of contact as the administrative barriers are kept low. This allows the NNIN facilities to be very responsive to users’ needs and to new research directions.

Electronics

Two-Color Single-Bump Quantum Dot Camera

Researchers at the University of New Mexico — E. Varley, M. Lenz, S.J. Lee, J.S. Brown, D.A. Ramirez, A. Stintz, and S. Krishna — developed an infrared focal plane array (FPA) capable of examining two colors of infrared spectra. They developed this two-color camera by fabricating a hybrid of a quantum-well infrared photo detector (QWIP) and a quantum-dot infrared photo detector (QDIP). This hybrid structure is known as dots-in-a-well, or DWELL, detector. The device they developed demonstrates multicolor response ranging from mid-wave infrared (MWIR at 3-5 μm) to long-wave infrared (LWIR at 8-12 μm). The UNM researchers developed this two-color single-bump DWELL focal plane array using molecular beam epitaxy coupled with a single indium bump for each pixel in the resulting matrix. A commercial partner, QmagiQ LLC (Axel Reisinger and Mani Sundaram), hybridized the FPA to a commercial readout circuit. The following images demonstrate the single-bump FPA and examples of the two-color response.



Single Electron Transistors

Neil Zimmerman of the National Institutes of Standards and Technology has used the Cornell facilities to fabricate single-electron transistors for electrical metrology applications. This work centers on fabrication of silicon (Si) nanotransistors with multiple levels of gates, for two purposes: silicon single-electron tunneling (SET) devices at low temperatures, and electrostatic sensing of charge reconfigurations in fluids at room temperature. The SET devices are based on Coulomb Blockage physics and when fabricated in silicon can have much reduced charge offset drift. Those shown here are fabricated on silicon-on-insulator (SOI) wafers; with back gate, the active layer, two layers of poly-Si gates, and metallization; the process flow has about 60 steps.

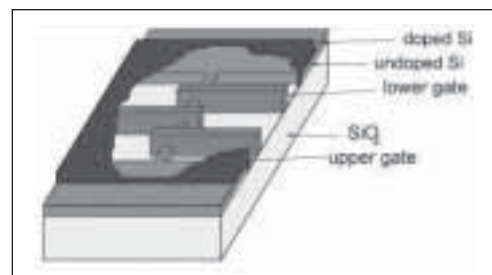

Figure 1: Schematic of single-electron tunneling multi-gate device

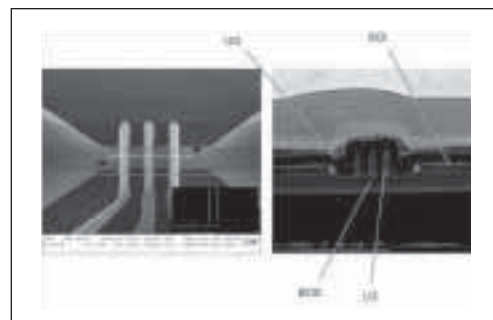

Figure 2: (left) Top-down view before upper gate fabrication. (right) Cross-sectional view after complete fabrication process

Photonics

Photonic Crystal Devices

Phillippe M. Fauchet, University of Rochester, uses the NNIN facility at Cornell to develop new electro-optical switching devices. By forming a lattice of macroscopic dielectric media, an optical analogy of a crystal, called a photonic crystal, can be fabricated. This investigation uses silicon fabrication techniques to construct photonic bandgap structures with the capability of manipulating light for potential all-optical silicon-based optoelectronic circuits.

With careful tuning of the local lattice constant in the center region of a 2D photonic crystal, resonators with a measured Q factor of the order of 10,000 have been fabricated. If the refractive index of part of the materials is changed — for example, the air holes are filled with EO materials like liquid crystal or EO polymer — and its refractive index is changed by thermal effect or electric field, it is possible to have very high on/off extinction ratio transmission signal for some particular wavelengths. An SEM image of the device is shown below. A second type of 2D photonic crystal resonator was made containing aluminum electrodes fabricated near the resonator. By filling the photonic crystal with liquid crystals, the resonance can be red- or blue-shifted by applying an electric field across the electrodes.

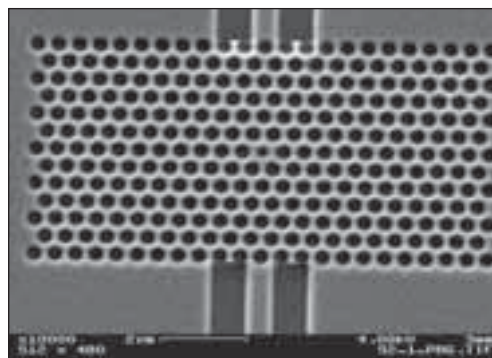

Photonic crystal

Compact Bandwidth Tunable Micro-Ring Resonators

Optical resonators have vast applications in optical systems. One important characteristic of an optical resonator is its bandwidth. For some applications, such as dynamically configurable filters and optical storage devices, a resonator of tunable bandwidth is desired. Michal Lipson of Cornell has fabricated and tested compact micro-ring resonator where the bandwidth can be tuned over a broad range using the thermo-optical effect.

The devices were fabricated on a Unibond silicon-on-insulator (SOI) substrate at the Cornell NanoScale Facility. The waveguide and micro-ring are 520 nm wide and are defined by electron-beam lithography. Subsequently, thermal heaters are then patterned on top of the bus waveguides with electron-beam lithography, evaporation and lift-off process.

The devices were tested with a TE-like polarized light from a wavelength-tunable laser. The bandwidth and extinction ratio can be tuned as the researchers drive the micro-heaters to tune the effective coupling.

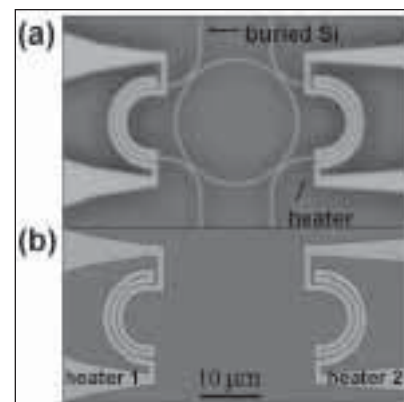

Micro-ring resonators

NNIN Research Impact

MEMS (Microelectromechanical Systems)

Highly Compliant Gimbaled AFM Probes

The atomic force microscope (AFM) is a critical instrument for “seeing” and measuring nanostructures. Nanotechnology is in fact used to fabricate the most critical part of the AFM, the highly sensitive probe which is used to “feel” the surface with atomic resolution. Highly sensitive AFM levers that have minimal moving areas and lower noise have been fabricated using NNIN facilities. The fabrication process was developed and optimized at the Cornell NanoScale Facility by researchers. It requires 4 contact photolithography layers and allows us to produce a highly compliant and ultra-small (20x20µm) torsion. These levers allow more sensitive operation in liquid and better thermal stability than commercially available AFM probes. This fabrication process allows for design flexibility in 3 dimensions allowing production of dual-axis gimbaled levers. These levers have two sets of orthogonally-arranged soft SiN hinges onto which were mounted a pad and a gimbaled mount.

Frederick Sachs of the State University of New York at Buffalo at the Cornell NanoScale Facility.

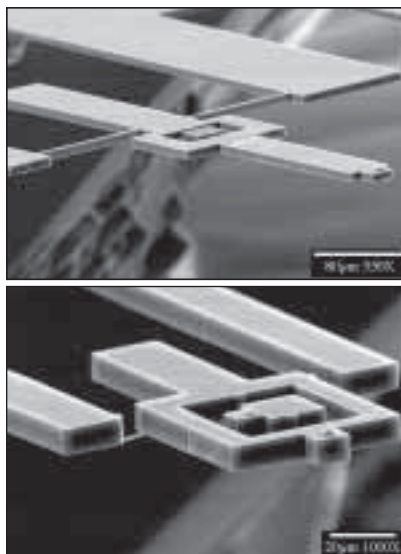

Piezoelectric Microcantilever Sensors

Small vibrating cantilevers can be used as ultrasensitive mass detectors. The mass of even a small virus or bacteria is sufficient to significantly change the vibrational properties of such cantilevers.

This piezoelectric micro-cantilever sensor (PEMS) consists of a piezoelectric layer, lead zirconium titanium (PZT), and a non-piezoelectric layer, SiO₂. The device can self-excite and self-detect mechanical resonance electrically for various sensing applications.

The 40 µm long PEMS demonstrated 6×10⁻¹⁶ g/Hz mass detection sensitivity for humidity detection. It is the smallest and most sensitive PZT-based PEMS in the world so far.

Z. Shen, W. Y. Shih and W-H Shih — Drexel University — using the NNIN facilities at Penn State.

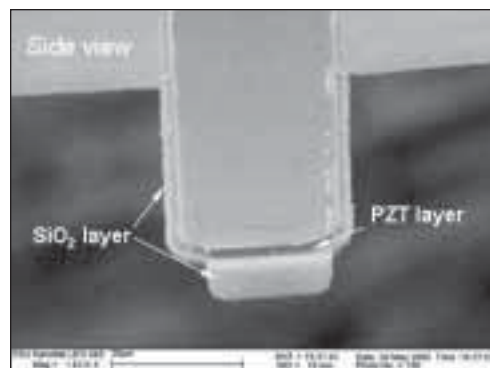

Nanoscale Physics

GMR Spin Valve Sensors

Su Gupta from the University of Alabama has developed GMR spin valve sensors using E-beam lithography at Georgia Institute of Technology. GMR sensors enable creation of portable communication systems with enormous memory storage. The advantages of these magnetic devices include increased data-processing speed, decreased electric power consumption, and non-volatility (memory is maintained even when the power to the device is turned off).

The current perpendicular to the plane (CPP) geometry, when the current is flowing perpendicular to the film plane, is expected to deliver the maximum sensitivity (GMR ratio). The challenge is to increase the output signal by creating a current confined path (CCP) within the magnetic stack. This was achieved by reducing the contact

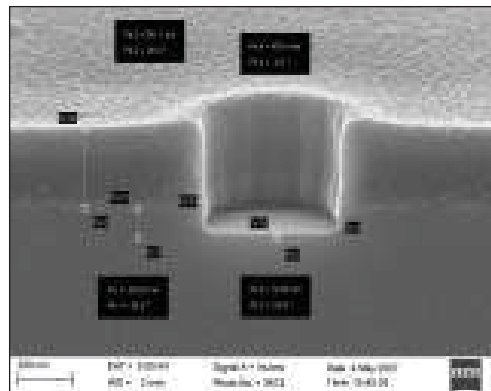

area between the top electrical lead and the magnetic stack. The e-beam lithography tool at the MiRC helped in the successful stack definition and in opening the contact hole (100 nm) in the interlayer insulator.

Improvements in the performance of GMR sensors are underway via the fabrication using e-beam lithography tool at the Georgia Tech site.

Biology and Chemistry

Multielectrode Arrays for Biochemical Recording

Multi-electrode arrays (MEA) have been widely used as a noninvasive *in vitro* recording method to study excitable cells and tissues, such as peripheral neurons, stem cells, or sliced brain tissue. The limitation for a conventional MEA system is the accuracy of the response of an individual-cell-based neuronal network.

Research has developed a novel MEA system with the capability to culture neuron cells in predefined patterns on top of electrodes that can record the signals of excited neuron cells.

Svetlana Tatic-Lucic, Lehigh University, using the NNIN facilities at the Cornell NanoScale Facility.



Fabricated multi-electrode array for guided neural growth



SEM of a single probe in the MEA

Flexible Sensors for Diagnostic Applications

Scientists at the Center of Advanced Microelectronic Manufacturing (CAMM), a research center at Binghamton University in New York State, are developing tooling and processes to use unsupported flexible polymeric substrates. In particular, flexible copper microelectrode devices have been fabricated using unsupported poly(ethyleneterephthalate), or PET, substrates for use in low-cost, disposable sensor applications. Other possible applications include chemical sensors (volatile organic compound sensing), medical diagnostics and other microelectronic applications.

This research demonstrates the feasibility of fabricating flexible copper microelectrodes on flexible unsupported PET substrates using the microfabrication facilities at the NNIN facility at Cornell.



Flexible sensor array

Nanoparticle/Microfluidic based Electrochemical Biosensors

Kathryn Keller (U.S. Center for Disease Control) and Peter Hesketh (Georgia Tech) have developed a microfluidic device for biochemical assays. Immobilization of biospecific molecules onto micro/nanoparticle surfaces increases the available binding surface area per unit volume. Furthermore, using a particle-immobilized reagent allows localization of the biomolecular interaction to a specific point in the analysis system.

The role of the enzyme is to produce the electroactive species for electrochemical detection of the proteins. The paramagnetic particles located over an array of 2.4 micron-wide sized interdigitated Pt electrodes, along with small counter and reference electrodes fabricated of silicon chip and integrated with PDMS, microchannel to form a miniaturized electrochemical cell. Successful IL-8 (antigen) conjugation of antibody-antigen-antibody-enzyme complex was achieved using this fabricated biosensor at the MiRC, the Georgia Tech NNIN site.

With this device the attachments of proteins or toxins can be monitored via electrochemical sensing methods. The study of antigen-antibody interactions can be achieved via the fabricated biosensor.

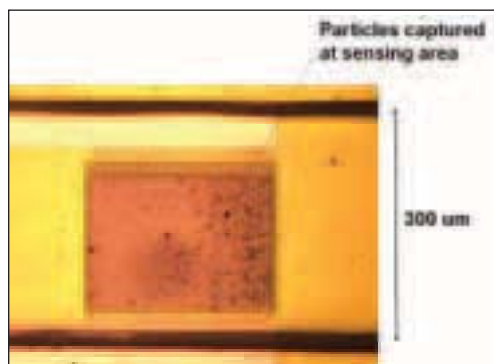

Miniaturized electrochemical cell

Model Neural Protheses with Integrated Microfluidics for Drug Delivery

The successful use of brain implants to treat chronic diseases requires stable two-way electrical communication between neurons, the electrically communicating cells of the brain, and the implant. This level of biocompatibility can likely only be achieved with continuous pharmacologic intervention that is changed as a function of time. Thus, incorporating drug-delivery systems into our brain implants is critical.

James N. Turner, New York State Department of Health, has worked at the Cornell NanoScale Facility to make microfabricated neural probes with a novel U-channel design using DRIE. The U-channel design has advantages in terms of changing the drug regime and for delivering controlled high concentrations of drug.

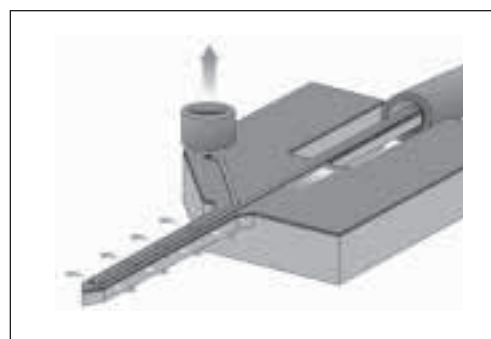
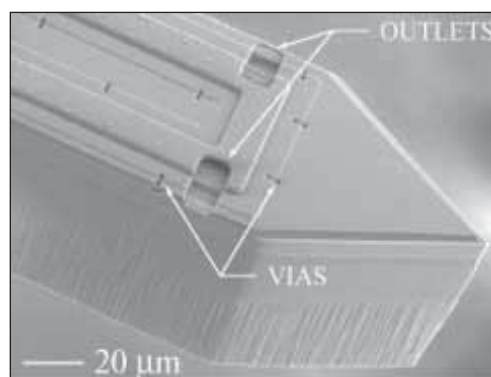

Nanotechnology Materials and Processes

Nanofountain Probes

Horacio Espinosa of Northwestern University uses the Cornell facility to fabricate nanofountain probes (NFPs), a novel type of atomic-force microscopy (AFM) probe designed to pattern planar substrates with molecular inks in the 50 nm – 1 μm range. These probes extend the “dip-pen nanolithography” mode of patterning, by increasing the writing speed and eliminating the need for disruptive re-inking and subsequent probe realignment. This is accomplished by supplying fluid ink from on-chip reservoirs through microchannels to the probe tips. A volcano-shaped aperture, shown below, keeps the fluid ink as close as possible to the probe-substrate contact point, without allowing a real flow over the substrate. This is essential to achieving sub-100 nm lines and avoids the formation of outer menisci (droplets) being dragged over the surface, as is the case with nanopipette and apertured probe writing devices.

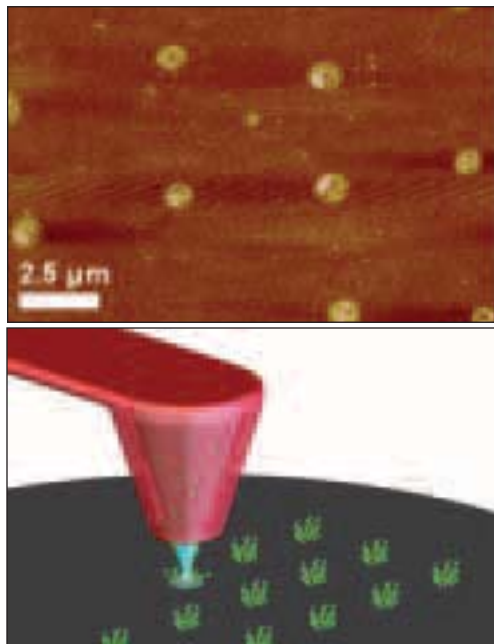

Graphene Mechanical Resonators

David Tannenbaum of Pomona College, and Harold Craighead, Paul McEuen, and Jeevak Parpia of Cornell have facilities at the Cornell NanoScale Facility. Nanoelectromechanical systems were fabricated from single and multilayer graphene sheets by mechanically exfoliating thin sheets from graphite over trenches in SiO₂. Vibrations with fundamental resonant frequencies in the MHz range are actuated either optically or electrically and detected optically by interferometry. A Young’s modulus of 1 TPa was measured. Most suspended sheets were under tension. The quality factors of the suspended graphene sheets are in the range of 20–850 and show no dependence on the thickness. The thinnest resonator consists of a single suspended layer of atoms and represents the ultimate limit of two dimensional nanoelectromechanical systems.

The application of graphene NEMS extends far beyond just mechanical resonators. This robust conducting membrane can act as a nanoscale supporting structure or atomically thin membrane separating two disparate environments.



SEM image of suspended graphene sheet

Lithographically Designed Colloidal Particles

A method to produce well-defined, lithographically designed, nonspherical colloidal particles has been developed by Cornell's Abraham Stroock at the Cornell NanoScale Facility. The work demonstrates that formation of a highly anisotropic structure in a model system of Brownian cylindrical particles can be achieved by precisely controlling electrostatic, van der Waals and depletion interactions, as well as the surface properties of the particles. The method can also be used to produce a diversity of particles of more complex shape, and thus opens the road to the formation of a broad diversity of structures at the colloidal scale.

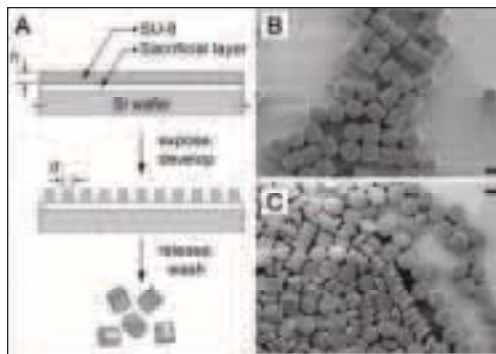

(A) Schematic diagram of formation of cylindrical particles in an epoxy-based negative photoresist (SU-8) via projection photolithography. (B and C) SEMs of SU-8 particles produced by this process and redeposited on a silicon wafer from water.

Shaped Controlled Synthesis of Gold NanoCages and Applications in Cancer Research

Work by Hui Zhang, at the University of Washington in St. Louis, shows the promise of nanotechnology for treating diseases such as cancer. High-yield single crystal silver nanoparticles were synthesized for the first time in solution through the addition of chloride to a standard polyol synthesis. These nanoparticles, a mixture of cubes and tetrahedrons characterized by truncated corners and edges, have particle diameters ranging from 20–80 nm. The single crystals are formed because defects inherent in twinned nuclei of silver lead to selective etching and dissolution by chloride and oxygen (from air). Through a simple galvanic replacement reaction, monodisperse 30 nm silver particles synthesized by this method were converted to 40 nm gold nanocages. Taking advantage of their extremely high extinction coefficient in the near-IR (800 – 1000nm, transparent window for soft tissues), the researchers subsequently functionalized gold nanocages with tumor antibodies to enable contrast-enhanced imaging of cancer tissue and photodynamic therapy of tumor cells. This approach has large potential for cancer therapy.

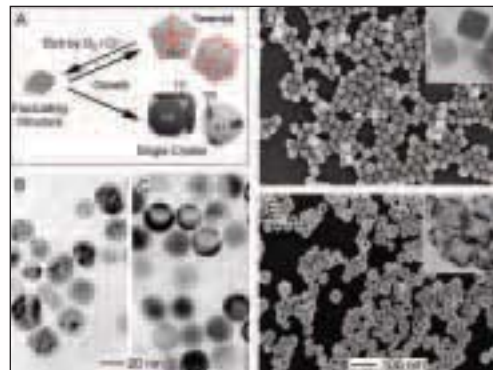

Human Resources Impact

Undergraduate Research

NNIN conducts a highly successful **Research Experience for Undergraduates (REU)** program in nanotechnology, with 70 total participants each summer at 12 NNIN sites. This program has been conducted for 12 years (as NNIN and NNUN) with a total of more than 500 alumni participants. The primary goals of this program are to introduce students to careers in nanotechnology and encourage talented students to pursue graduate degrees in science and engineering.

Our program consists of a 10-week intensive research experience at one of the NNIN laboratories under the tutelage of faculty, staff, and graduate students associated with NNIN. To assure a quality experience, projects are carefully chosen and closely monitored. NNIN's expertise in training users quickly and efficiently is put to good use in the REU program. With proper planning, strong mentoring, and supervision, students are able to learn about both the research experience and nanotechnology and complete a quality research project.

Our program specifically targets recruitment of women, minorities and students from smaller non-research colleges, although the participant pool broadly represents the available student body. National recruitment at a broad spectrum of institutions and a unified on-line application help enhance the applicant pool. More than 500 applications are received each year for 70 available positions, allowing us to be very selective.

The program culminates with the NNIN REU Convocation, which is a small scientific conference of all the NNIN REU participants. At the convocation, each student presents research results to fellow NNIN REU participants and to staff and faculty who also attend. For many of our students, this is their first scientific presentation. The preparation for the presentation and the professional and social networking with peers adds significantly to students' REU experiences.

All participants write a research report on their summer project, which is published in the *NNIN REU Research Accomplishments*. These are also available online at www.nnin.org/. In addition, many results are published in the regular literature with the students as co-authors.

As a program with over 10 years of experience and over 500 participants, NNIN is uniquely positioned to evaluate the long term effect of such undergraduate research programs. As encouraging graduate school is one of the primary objectives of the program, the results only play out over an extended 5-10 year period after participation. To evaluate the effectiveness of our program and of REU programs in general, we have begun a longitudinal study of the early participants in our program to assess their final education and career outcomes. Initial data from the earliest participant in our program (1997-2002) indicate that 40% of participants end up with Ph.D. degrees, and more than 90% remain in a scientific career. These data show that REU programs can have a significant effect on the development of the science and engineering talent that is critical to U.S. competitiveness.

Graduate Students

Approximately 75 percent of the 4,500 annual users of NNIN are graduate students. These students are enrolled not only at the 13 NNIN universities, but also at hundreds of other academic institutions around the country. They are enrolled in M.S. and Ph.D. programs within physics, materials science, electrical engineering, mechanical engineering, chemistry, biology, and other fields. The advanced NNIN facilities make it possible for them to pursue research using equipment and techniques that are not available at their local universities. NNIN is responsible for more than 800 Ph.D.s per year, across all nanotechnology areas. This represents a significant portion of the new nanotechnology talent in the U.S.

In addition to equipment access, NNIN training is highly desired and an important part of NNIN's contribution. Student users who come to NNIN facilities are trained on the use of sophisticated nanotechnology equipment. Our facilities are for the most part hands-on user facilities. The students take this training back with them and are better able to use nanotechnology facilities wherever they work. In particular, our safety training is highly valued, with a scope extending far beyond our own laboratories.

NNIN facilities also offer a variety of short courses and workshops intended to introduce students to the possibilities available within nanotechnology and to increase their level of expertise in particular technical areas. While these workshops are open to all, they are especially valuable to the graduate students within the NNIN user base. In this way we are able to leverage the considerable expertise and experience of our staff to have an even broader impact.

Developing Global Scientists

Scientific research, and in particular nanotechnology research, is becoming an increasingly international endeavor. While students from foreign countries become well aware of this important facet of science early in their careers, U.S. students are considerably less prepared. Few U.S. undergraduates have even considered the advantages, the difficulties, or the necessity, of studying or working abroad.

Since companies likewise have an increasing number of international research and production facilities, students with international scientific experience are in increasing demand.

NNIN has established several new programs to introduce undergraduate students to the international aspects of research at an early stage, using its successful REU program as a filter and feeder program. Students who have completed our NNIN REU program are well prepared for a second major research experience that will further their interest in a nanotechnology research career. And our direct experience with them during their research gives us the ability to choose those who are most able to take advantage of an advanced international research opportunity.

Through programs at the National Science Foundation to support the development of globally aware scientists, NNIN has secured funding to send five of the best of our REU students for a second summer experience at the National Institute of Materials Science in Tsukuba, Japan, and to send three students to the Helmholtz Research Center in Jülich, Germany. Eight additional superior students will be placed in U.S. national laboratories. For these programs, the NNIN REU program will act as the sole feeder program, assuring these programs a stream of highly qualified students with a serious interest in a nanotechnology career.

Human Resources Impact

Diversity

Full participation by women and underrepresented minorities is critical to developing the 21st century nanotechnology workforce. Because of its popularity in the media, nanotechnology is an excellent vehicle for capturing student attention. NNIN, with its high visibility and national scope, plays a key role in bringing science in general and nanotechnology in particular to the minority student community.

In addition to its REU program, which reaches a significant underrepresented population, NNIN has instituted several new programs to address diverse participation in nanotechnology.

Laboratory Experience for Faculty

Minority faculty and faculty at minority serving institutions are key to stimulating interest in nanotechnology within a diverse student

community. The user support mechanisms and training mechanisms of NNIN are well suited for bringing nanotechnology into new communities, and so NNIN has started the NNIN Laboratory Experience for Faculty program to stimulate nanotechnology interest at the faculty level.

This program operates much like the REU program for students, with participating faculty in residence at an NNIN site for 10 weeks, where they work closely with NNIN staff and NNIN-associated faculty. In some cases, they will be interested in launching a research program of their own in nanotechnology. In other cases, they will view the program as an enrichment opportunity, allowing them to bring nanotechnology applications into their course offerings. The program stimulates nanotechnology interest at the student level,





with long-term impact on the diversity of national graduate student population and the NNIN user base.

This program will begin in summer 2008 with five participating faculty at various NNIN sites.

Nanotechnology Showcase

NNIN has developed a Nanotechnology Education and Careers Showcase to encourage underrepresented minorities to pursue nanotechnology careers. This showcase, developed for presentation at national and regional conferences, begins with a series of introductory nanotechnology presentations (three hours). Particular attention is paid to exposing the students to the variety of nanotechnology careers and to the multiple educational tracks available to pursue such a career. The target audience is first- and second-year undergraduates who are still making education and career plans, although the content is general enough to be of interest to a broad spectrum of students and professionals.

To put the introductory content into perspective, an afternoon session offers a variety of nanotechnology demonstrations. Portable nanotechnology equipment including a tabletop scanning electron microscope, a scanning tunneling microscope, fluorescence microscope, and MEMS and microfluidics demonstration platforms are set up at demonstration stations to engage students in real demonstrations of nanotechnology equipment and concepts.

The showcase was presented for the first time at the Society of Hispanic Professional Engineers Annual Conference in November 2007 to an enthusiastic group of prospective nanotechnologists. NNIN expects to offer this showcase several times per year at the major engineering conferences serving the target population.

Human Resources Impact

Nanotechnology Education and Training

NNIN has a large integrated education and outreach program primarily directed to support development of a workforce ready for the demands of the rapidly developing field of nanotechnology, as well as to develop a nano-literate public.

The National Science Foundation estimates that by the year 2015 there will be a need for two million workers worldwide in the fields of nanoscience and nanotechnology. An additional five million workers will be needed in support areas for these fields.

NNIN believes that outreach activities must begin in the elementary grades and extend to the professional level for those in need of retraining and skill enhancement. An important goal of this outreach is to excite secondary and post-secondary students to enter the fields of science, technology, and engineering — in particular nanotechnology. NNIN has termed this need as “K-gray” education and is implementing programs to reach all facets of society in order to educate people about nanoscale science and engineering.

NNIN has four overarching goals that drive its education efforts:

- Expose young people to advanced and exciting research in nanotechnology and motivate them to prepare for careers in the sciences or engineering
- Train teachers about the discipline of experimental sciences, provide additional teaching tools, and enhance their enthusiasm for encouraging students’ pursuit of careers in science
- Create and distribute educational materials for children, college students, technical professionals, teachers, and the general population
- Focus these efforts on population segments that have disproportionately low representation in sciences

From these overarching goals, specific programmatic objectives have been established that have an impact at the national or local scale. Some of our programs are local in scope (community days, tours, school visits) while others have a national focus (Research Experience for Undergraduates/ Teachers, technical workshops). NNIN education and outreach programs reach a wide variety of individuals, including K-12 students and teachers, undergraduate students, graduate students, post-doctoral associates, faculty and other professionals, and the general public.



The National Science Foundation estimates that by the year 2015 there will be a need for two million workers worldwide in the fields of nanoscience and nanotechnology.



Among the NNIN education activities with the highest impact and visibility are:

- **Nanooze** — www.nanooze.org, a nanotechnology-oriented science web-zine for children (pre-teen)
- **NanoExpress** — a mobile nanotechnology laboratory developed by the NNIN Howard University site, bringing nanotechnology resources to schools and public events
- **Research Experience for Teachers** — a program to engage high-school and middle-school teachers in research as a way to increase student awareness of nanotechnology
- **Research Experience for Undergraduates** — summer research program
- **Workshops** — dozens of technical workshops and short courses for teachers, graduate students, and professionals
- **Day camps and day activities** — for high-school and middle-school students

All NNIN educational materials are accessible via the web at education.nnin.org.

Current NNIN events are listed at www.nnin.org/nnin_events.taf.





User Profiles

A sampling of the diversity of the NNIN user community.

Robert Austin

Princeton University,
Department of Physics

Nanobiotechnology



Professor Austin was one of the early pioneers of the application of nanotechnology to biology and biophysics. He began his work at the Cornell facility in 1991. Since then 42 of his students have used CNF, resulting in 11 Ph.D. degrees. Austin jokes that he has traveled approximately 175,000 miles to use CNF (450 miles, twice a month, for 16 years), or approximately 75 percent of the distance to the moon!

Austin was one of the first to use microfluidics for biological applications. His work includes a variety of microfluidic devices used for sorting and analyzing cells and DNA.

Francis M. Gasparini

Physics Dept., University at Buffalo,
The State University of New York

Coupled Arrays of Superfluid Helium
Confined to Zero Dimensions



The research group of Professor Frank Gasparini has been using the CNF since 1994. Six graduate students and one post-doc have made use of the facility since the inception of the project. They construct structures used to confine liquid helium in one, two, or all three spatial dimensions, which allows them to study finite-size effects in liquid helium. The most recent investigation involves the coupling together of small zero-dimensional regions of superfluid helium via a film of normal helium that should not promote this coupling. This is analogous to the proximity effect seen in superconductors.

User Profiles

Michael Hochberg

University of Washington
Electrical Engineering
Nanophotonics



Michael Hochberg has been a user at the Cornell facility since 2002, initially as

a student at Caltech. The excellent electron beam lithography and etching capabilities provided by the CNF were critical for this work, which required building structures in silicon with features on the sub-50 nm scale. Based on his work at Cal Tech, Hochberg has been hired into a faculty position at the University of Washington, where he is pursuing a research agenda aimed at creating practical, low-power, chip-scale nonlinear optical devices. By taking advantage of high-nonlinearity polymer claddings in combination with the extremely high field concentration available in silicon waveguides, he has been able to build a number of novel nonlinear devices. These include an all-optical modulator working at a bandwidth in the terahertz, operating with low power, continuous-wave inputs. This work will continue to rely heavily upon the resources at CNF.

Xiaohua Huang

Department of Bioengineering
University of California, San Diego
Microfabricated Arrays for
Genome Sequencing



Huang and his students are developing a novel method for fabricating nano-arrays

of biomolecules on chemically derivatized glass slides using photolithography and the self assembly of functionalized nano particles. They use University of California, Santa Barbara lithography facilities to generate nano-arrays through controlled etching of submicron features and the attachment of nanometer-scale polystyrene beads within these elements via biotin-streptavidin binding. This approach is being used to construct high-density arrays of single biomolecules for conducting extremely high-throughput genomic and other biomolecular analyses. This technology may also be applied to the manufacturing of the next generation of biological sensors and electronic devices. Lithography work is done in the UCSB facility by student Kris Barbee and has been ongoing and regular since January 2006. Huang says, "Our research would not have been possible without the UCSB Nanotech Facility and the help from the staff."

Weidong Zhou

Electrical Engineering
University of Texas at Arlington
NanoPhotonic Device Research



Weidong Zhou and his co-workers have been fabricating photonic crystal surface emitting

lasers (PCSEL) at MRC at the University of Texas at Austin since February 2005. The PCSEL program objectives are the fabrication of nanoscale lasers on silicon with efficient electrical injection and wide spectral coverage. With colloidal quantum dots encapsulated into the photonic crystal cavities for lasers on silicon, the gain threshold is reduced.

The first year of Zhou's work at MRC UT-Austin, the e-beam technical expert at MRC did the writing and dry-etch patterning. Since 2006, HongJun Yang, Zhou's graduate student, has been trained on the equipment at MRC UT-Austin and can now work independently of facility staff.

Yong Xu

Electrical Engineering
Wayne State University

Parylene Microcantilevers for Biochemical Sensing; Artificial Retinal Implants; Tactile Sensors for Minimally Invasive Surgery



Professor Yong Xu conducts research on MEMS and biomedical electronics with

three students at the Michigan Nanofabrication Facility. One of his many projects is to develop artificially implantable, high-density stimulating electrode arrays integrated with microelectronic circuits for people blinded by retinal diseases. Prof. Xu's research program also includes development of polymer micro-cantilevers for use as biosensors for DNA hybridization and antigen-antibody binding, and as chemical sensors. Much of Prof. Xu's device fabrication work takes place at the Wayne State University Cleanroom, but he has also been using the NNIN's Michigan Nanofabrication Facility for the past two years.

"MNF (The NNIN site at the University of Michigan) has been of immense help for my entire group. It gives us a one-stop shop for all our fabrication needs and complements our research facility at Wayne State very well."

— Yong Xu

Frank Vollmer

Biofunctional Photonics Group
Roland Institute at Harvard University
Silicon Based Photonics For Biosensing



Professor Vollmer, a new Junior Fellow at the Roland Institute at Harvard, has

only recently begun using the NNIN facilities at CNF. He is investigating photon confinement in disordered two-dimensional photonic crystals.

The design concept involves structural perturbations that are distributed uniformly throughout the artificial crystal by deliberately changing shapes and orientations of its lattice elements. The nanometer-scale disorder created in this way represents random scatterers that impede propagation of Bloch-waves through the otherwise periodic lattice. Slow-modes guided along line-defects in disordered crystals experience coherent backscattering which results in photon localization. The effect is observed in a narrow band close to the guided mode's cutoff where the interaction with disorder is strongest. Confined resonances with Qs of $\sim 150,000$ and sub-micron cubed modal volumes have been observed.

Ania Bleszynski

Graduate Student
Yale University, Advisor: Jack Harris

Fabrication of Sensitive Microcantilevers with Integrated Mesoscopic Samples



Ania has been a user at the Cornell Facility for only eight months, fabricating

cantilevers as torque magnetometers to study the magnetic properties of small metallic samples. In particular, this project focuses on measuring persistent currents in normal metal rings, a purely quantum mechanical phenomenon that emerges in very pure, micron-scale samples at low temperatures. Extremely high sensitivity of the cantilever-based detector is essential to the success of the measurement. In only a few months, they have succeeded in fabricating cantilevers with integrated aluminum rings that have measured force sensitivities of $\sim 1\text{aN/Hz}^{1/2}$ corresponding to a magnetic moment sensitivity of $10\ \mu\text{B/Hz}^{1/2}$. Both the staff and the equipment at the CNF have been indispensable in achieving these results.

"I have been thoroughly impressed with the staff's knowledge, willingness to help, and dedication to making the CNF a welcome place for outside users."

— Ania Bleszynski

User Profiles

Eunki Hong, Ph.D.

Bridge Semiconductor Corporation
Thermal Imaging Sensor —
MEMS Processing Development



Eunki Hong, Ph.D., works as a MEMS process engineer for Bridge Semiconductor, a start-up company, that is developing infrared imaging modules and cameras based on complex oxides. This project has been ongoing since November 2006. Hong's previous research focused on polymer-based high-density interconnections and the project ran from February 2003 through November 2006. Hong has been a user of the nanofabrication facility at Pennsylvania State University for more than six years, including his graduate time. Currently, he is focusing on developing a process to etch complex oxide.

“Knowledgeable staff and state-of-art equipment at the Penn State NNIN facility enable my project to progress successfully.”

— Eunki Hong, Ph.D.

Massood Atashbar

Western Michigan University
Electrical Engineering
Development of Integrated Surface
Acoustic Wave Sensing Systems; Early
Detection of Prostate Cancer

Professor Massood Atashbar is the Director of the Center for Advanced Smart Sensors and Structures and also of the Sensor Technology Laboratory at WMU. Two of his research projects make use of the Michigan Nanofabrication Facility. One important research topic, the early detection of prostate cancer, is addressed by his work in developing MEMS-based sensors that can detect biomolecules in liquid. His other project involves the development of sensors that can withstand inhospitable environments and are powered passively so that they can be deployed without batteries. Prof. Atashbar began using the Michigan Nanofabrication Facility in 2003.

Robert Hower

Evigia Systems, Inc.
MEMS Sensors for RFID Applications

Dr. Robert Hower and his colleagues at Evigia Systems are working to make commercial and government supply chains safer and more efficient by developing RFID tags and sensors that are smaller, cheaper, and have multiple functionalities. Dr. Hower has worked at Evigia Systems since March 2007, and much of his time has been spent in the Michigan Nanofabrication Facility developing prototype accelerometers and sensors for temperature and humidity measurement. After developing prototypes, Evigia Systems plans to take its processes and designs to foundries to manufacture its devices on a large scale. Dr. Hower says that Evigia Systems' use of the MNF for prototype development is critical at this stage of the company's progress, as it allows them to “turn ideas into real objects.”

Raymond Vrtis, Ph.D.

Air Products and Chemicals Inc.
Deposition of Barrier/Etch Step Layers
Using Novel Precursors

Dr. Raymond Vrtis is a Ph.D. chemist with more than 15 years' experience working on new materials in the microelectronics industry. He has been working at the nanofabrication facility at Penn State on a variety of novel materials and chemicals for use in the deposition and integration of advanced dielectric materials for interconnect technology. Air Products and Chemicals has a long history of working with Penn State on a variety of projects. The current project began in 2004.

“Using the capabilities available at the Nanofab has allowed us to screen new and novel chemical precursors on a state-of-the-art tool that can be quickly translated to our customers. Having this capability at Penn State has enabled Air Products and Chemicals to run programs that we might not otherwise have run, and has resulted in at least one material that has been successfully transferred to a customer”.

— Raymond Vrtis, Ph.D.

Wook Jun Nam

Research Associate
Penn State University
Stamp Fabrication for IMPRIO 55



Wook Jun Nam and his co-workers are exploring a new approach for manufacturing

ordered nano structures. The Step-Place-Grow Assembly approach will utilize a reusable template to create nano structures that can be either totally grown in place or assembled in place from previously made nano-powders, tubes, wires, rods, and fibers.

The researchers have been remote users at the MRC facility at the University of Texas at Austin since Nov. 2005 for the purpose of fabricating masters for imprint lithography using the template fabrication process there. Pattern design files and quartz substrates are sent to the MRC where they are exposed using e-beam lithography and etched with RIE to form the imprint template.



NNIN Users Institutions: Academic, Industry, and Government

Within its user base, NNIN counts users from more than 175 academic institutions. These include many of the major research universities as well as smaller universities and four-year colleges in almost every state.

Industrial users are critical to the mission of NNIN. They provide needed critical mass to support the operation of the facilities. They also provide fresh ideas and process discipline that benefit all users. Conversely, many industrial users find the academic environment refreshing and intellectually stimulating. Interaction between academic and industrial users, and among users in different fields, becomes mutually beneficial and is a powerful benefit of NNIN.

Both small and large companies are represented within the NNIN user base. Many of the larger companies have extensive nanotechnology facilities of their own. They find interaction with NNIN sites beneficial, however, due to the flexibility and availability, allowing the exploration of new processes and technologies without disturbing dedicated production or development tools. Most small business users lack the facilities necessary to develop nanotechnology products and are thus dependent upon NNIN facilities.

Academic

Albert Einstein College of Medicine
Arizona State University
Auburn University
Augsburg College
Austin Community College
Bethel University
Boston College
Bradley University
Brandeis University
Brigham Young University
Brooklyn College
Brown University
California Institute of Technology
California State University, Fresno
Carlow College
Carnegie Mellon University
Clarion University of PA
Clark-Atlanta University
Clemson University

Colgate University
Colorado School of Mines
Colorado State University
Columbia University
Cornell College
Cornell University
Cornell Weill Medical School
CUNY City College
Dartmouth College
Drexel University
Duke University
Eastern Nazarene College
Florida International University
George Washington University
Georgia State University
Georgia Institute of Technology
Hamilton College
Hamline University
Harvard University
Haverford College

Highline Community College
Howard University
Iowa State University
Ithaca College
Johns Hopkins University
La Sierra University
Lehigh University
Louisiana State University
Macalester College
Marquette University
Marshall University
Massachusetts Institute of Technology
McGill University
Michigan Tech University
Middlebury College
Montana State University
Montclair State University
Morehouse College
New Jersey Institute of Technology
New Mexico Tech
North Carolina State University
North Dakota State University
North Seattle Community College
Northeastern University
Northwestern University
Oklahoma State University
Old Dominion University
Pennsylvania State - Altoona
Pennsylvania State University
Pomona College
Prairie View A&M
Princeton University
Purdue University
Queen's University at Kingston
Rensselaer Polytechnic Institute
Rice University
Rochester Institute of Technology
Saint Cloud State University
Saint Francis University
San Jose State University
Santa Clara University
Shippensburg University
Skyline College
South Hampton University
Southern Illinois University
Southern Polytechnic State University
Stanford University
Stevens Institute of Technology
Sunmoon University (Korea)
SUNY Albany
SUNY Binghamton
SUNY Buffalo
SUNY Stony Brook

Syracuse University
Technion (Israel)
Texas A&M
Trinity University at San Antonio
Tufts University
University of California, Berkeley
University of California, Davis
University of California, Irvine
University of California, Los Angeles
University of California, Riverside
University of California, San Diego
University of California, San Francisco
University of California, Santa Barbara
University of California, Santa Cruz
University of Southern California
University of Texas at Arlington
University of Alabama-Tuscaloosa
University of Arizona
University of Arkansas
University of Central Florida
University of Cincinnati
University of Colorado
University of Connecticut
University of Dayton
University of Delaware
University of Florida
University of Georgia
University of Glasgow
University of Hartford
University of Houston
University of Idaho
University of Illinois-Chicago
University of Illinois Urbana-Champaign
University of Iowa
University of Louisville
University of Maine
University of Massachusetts-Amherst
University of Massachusetts-Lowell
University of Melbourne
University of Michigan
University of Minnesota
University of Minnesota-Duluth
University of Missouri-Columbia
University of Montreal
University of Nevada
University of Nevada Reno
University of New Hampshire
University of New Mexico
University of North Carolina
University of Notre Dame
University of Pennsylvania
University of Pittsburgh
University of Puerto Rico - Mayagüez

NNIN User Institutions

University of Quebec (Canada)
 University of Rochester
 University of Saint Thomas
 University of South Carolina
 University of South Florida
 University of Tennessee
 University of Texas at Arlington
 University of Texas at Austin
 University of Texas at El Paso
 University of Texas at San Antonio
 University of Toronto
 University of Vermont
 University of Virginia
 University of Washington
 University of Waterloo
 University of Wisconsin
 UT Health Science Center at Houston
 UT MD Anderson Cancer Center
 Utah State University
 Vanderbilt University
 West Virginia University
 Whitman College
 Whitworth University
 Winona State University
 Worcester Polytechnic Institute
 Yale University

Industry

3M Company
 454 Life Sciences
 A M Fitzgerald & Assoc.
 Acorn Technologies
 Active Optical Networks
 Advanced Diamond Tech.
 Advanced Nanostructures
 Advanced Optical
 Advanced Research Corp.
 Advanced Vacuum
 Advent Solar
 Advion BioSciences Inc
 AdvR Inc
 Aerius Photonics
 Aerojet
 Agave BioSystems
 Agile Materials & Tech.
 AgilOptics, Inc.
 Agiltron
 Agoura Technologies
 AIP Network, Inc.
 Air Products and Chemicals, Inc.
 ALCES Technology
 Allux Medical
 AMIA Laboratories, Inc.

Analom
 Anritsu
 Apic Corporation
 Apogee Technology Inc.
 Applied Biosystems
 Applied Nanostructures
 Applied Precision, LLC
 Applied Research & Photonics Inc
 Arrayed Fiberoptics
 Asbury Graphite Mills Inc.
 Aselsan
 Aspen Research Corp.
 Aspex
 Asylum Research
 ATDF
 ATK-GASL
 Atomate Corporation
 Aveka, Inc.
 Baker Hughes
 Battelle
 Becton Dickinson
 BeSang Inc.
 BF Goodrich
 BH Electronics, Inc.
 BinOptics Corp
 BioArray Solutions Ltd
 Bioforce Nanosciences
 BioScale
 BioVitesse, Inc
 Boeing
 Boston Applied Techn.
 Boston Scientific
 Brewer Science
 Bridge Semiconductor
 BTU International
 C2 Biotechnologies
 Calient Optical Compon.
 Cambridge NanoTech
 Cambrios
 Carbon Nanoprobes
 Cardiac Dimensions, Inc.
 Cardio Spectra
 CardioMEMS
 CardioMetrix
 Cargill, Inc.
 Cbrite
 Cellpoint Diagnostics
 Cerberex Technologies
 Ciba Specialty Chemicals
 Cima Nanotech
 Claro Chemical
 Clear Science, Inc.
 Collinear

Collinear Corporation
 Complete Genomics
 CorMine LLC
 Corning Incorporated
 Cree
 Crossfire Technology, Inc.
 Crystal Is, Inc.
 Cubic Applications
 CV Incorporated
 CVI Laser
 Cymbet Corporation
 Cyoptics, Inc
 Cypress Semiconductor
 CytomX
 Delta F Corporation
 Diagnostic Biosensors
 Digital Optics
 Disc Dynamics
 Displaytech
 DSM Solutions
 DuPont
 Eastman Kodak Company
 Ecolab, Inc.
 Edge Embossing, LLC
 Eksigent Technologies
 Emcore
 Entegris
 EnteroMedics, Inc.
 EPIR Technologies
 Etalon, Inc.
 Evergreen Solar
 Evigia Systems Inc
 Exponent Inc
 FLIR
 Fluxion Biosciences
 Freedom Photonics
 Fultec Semiconductor
 Gamma Company
 GEIT
 Gene Segues, Inc.
 General Electric
 General MEMS
 General Motors
 Giner Electrochemical Systems, LLC
 Glide/Write
 Global Nanosystems
 Grandis
 Guidant Corporation
 H² Scan
 Healionics
 Hewlett Packard
 Hitachi
 Hologic, Inc.

Hospira Corp.
 Hutchinson Technology
 Hyperion Catalysis Intl.
 Hysitron, Inc.
 IBM
 IFC Medical
 Ilypsa, Inc.
 Imation, Corp.
 ImTech, Inc.
 Infotonics
 Inlustra Technologies
 Innolume
 Innolume, Inc.
 Innovative Micro Technologies
 Intel Corporation
 Intergen Company
 International Specialty Products, Inc.
 Invenio
 Iolon
 Ion Optics, Inc.
 iRimsens
 Janson Aerospace
 JDS Uniphase
 Johnstech International
 Kent Optronics
 Kimberly-Clark
 Kionix Inc
 Kolo Technologies
 Kovio
 Kumetrix
 L-3 Communications
 Launchpoint
 LCM Technologies Inc
 Leak Indicator Paint
 Lexitek, Inc.
 LightConnect
 Lightsmyth
 Lintec Corporation
 Liquidia Technologies
 Lockheed Martin
 Los Gatos Research
 LSA, Inc
 Lucent Technologies
 Lumera
 Luminit
 Luxtera
 LW Microsystems
 Lyotropic Therapeutics,
 Mag Sil Corporation
 MagArray
 Mamac Systems
 MedShape Solutions
 Medtronic, Inc.

NNIN User Institutions

Meggitt Endeavor
MEMC
MEMS Optical LLC
MEMSCAP
Meng Technology
Metrosol Incorporated
Microcess
Microfab Technologies Inc
MicroGreen Polymers, Inc.
Microstaq
Microsurfaces, Inc.
Mitsubishi Chem Research
Modumetal
Molecular Imprints
Molecular Nanosystems
Molex
MSP Corporation
Multispectral Imaging
Nano & Micro Technology
Nano Dynamics – 88, Inc
Nano Liquid Devices
Nano Surface Analysis
NanoCoolers
Nanocopoeia, Inc
Nanocrystal Corp.
Nanofluidics
Nanohmics Inc
Nanojems
Nanolambda
Nanomaterials Disc. Corp.
Nanomix
Nanosys
Nano-Terra, LLC
Nantero, Inc.
National Recovery Sys.
Neah Power System Inc.
Nektar Therapeutics
Neokismet
Neophotonics
Nevada Nanotech Sys.
Ngimat (MCT)
nLight
Nonvolatile Electronics
Northrop Grumman
NovaSpectra
Nup2 Incorporated
NVE Corporation
NXTS
Olympic Precision
Olympus Microsystems
Omega Piezo
Optical Filter Sorce
Optobionics

Organic ID
Pacific Biosciences
Paddock Laboratories, Inc.
Parker Hannifin
PCB Piezotronics
Phillips Medical Systems
Phillips Plastics
Physics Innovations, Inc.
Piezo Resonance Innov.
Pirelli Labs
Pixtronix Inc.
Praevium Research
PrimeGen Biotech
Primet Precision Materials, Inc.
ProcessTek
Proteus Biomedical
Protochips
Qcept
QmagiQ
Qualtre
Quantum Logic Devices
qXwave, Inc.
Qynergy
Radiant Technologies, Inc.
Radiation Monitoring Devices, Inc.
Raymedica
Raytheon Infrared Operations
Raytheon RF Components
Raytheon Vision Systems
RedShift Systems
Research Triangle Institute
Revalerio Corp.
ReynoldsTech
RheoSense
Ropes & Gray, LLP
Royal Institute of Technology
RPIC Systems
Sachem
Sage Electrochromics, Inc.
Samsung
Satori Pharmaceuticals
Saxet Surface Science
SBA Materials
SCOLR Pharma
Scott Specialty Gases
Seagate Technology
SemiSouth Laboratories
Senspex
Siargo
Siemens
Sigenics
SIIMPEL
Siimpel Corporation

Silicon Quest, Inc
Singapore's Institute of Microelectronics
Sionyx, Inc.
Skyworks Solutions
Solarity
Solid State Measure. Inc.
Soligie Inc.
Soltaix
Solus Biosystems
SPEC
Spectrum Devices
Spiration
SRI International
St. Jude Medical
Standard Microsystems
Standard Steel LLC
Stanford Research
State of the Art
Stellar Micro Devices
Stion
Stryker Biotech
STS
SurModics, Inc.
SVT Associates, Inc.
Symetrix Corporation
Symyx Technologies
Target Technology Company LLC
TelAztec
Teledyne
TeraVista
The Bergquist Company
ThermoFisher Scientific
Thornn Micro
TIAX LLC
TLC Precision Wafer Technology
Total Lubricants USA, Inc.
TPL, Inc.
Transfer Devices
Translucent
Transonic Systems Inc
Transparent Optical
Transphorn
Trident Metrology
Triquint
TRS Ceramics
TRS Technologies, Inc
True Materials
Tyco Electronics
UltraClad Corporation
Unidym
Unity Semiconductor
Valspar Corporations
Varian Semiconductor Equipment

Veeco Metrology
Vesuvius Research
Victaulic Company
Visigen
Visileo Corp.
Waters Corporation
Wavefront Research, Inc.
Westover Scientific Inc.
Wilson Tool International
Winged Cat Solutions
WMR Biomedical, Inc.
Wostec
Xerox
Zeno Semiconductor
Zinc Matrix Power

Government

U.S. Air Force Research Laboratory –
Kirtland Air Force Base
U.S. Air Force Research Laboratory –
Wright-Patterson Air Force Base
Argonne National Laboratory
U.S. Centers for Disease Control
Lawrence Berkeley National Laboratory
Los Alamos National Laboratory
NASA Ames Research Center
National Institute of Standards and
Technology
National Institute for Occupational Safety
and Health
New York State Department of Health
Wadsworth Center
Oak Ridge National Laboratory
Sandia National Laboratory
Washington Technology Center

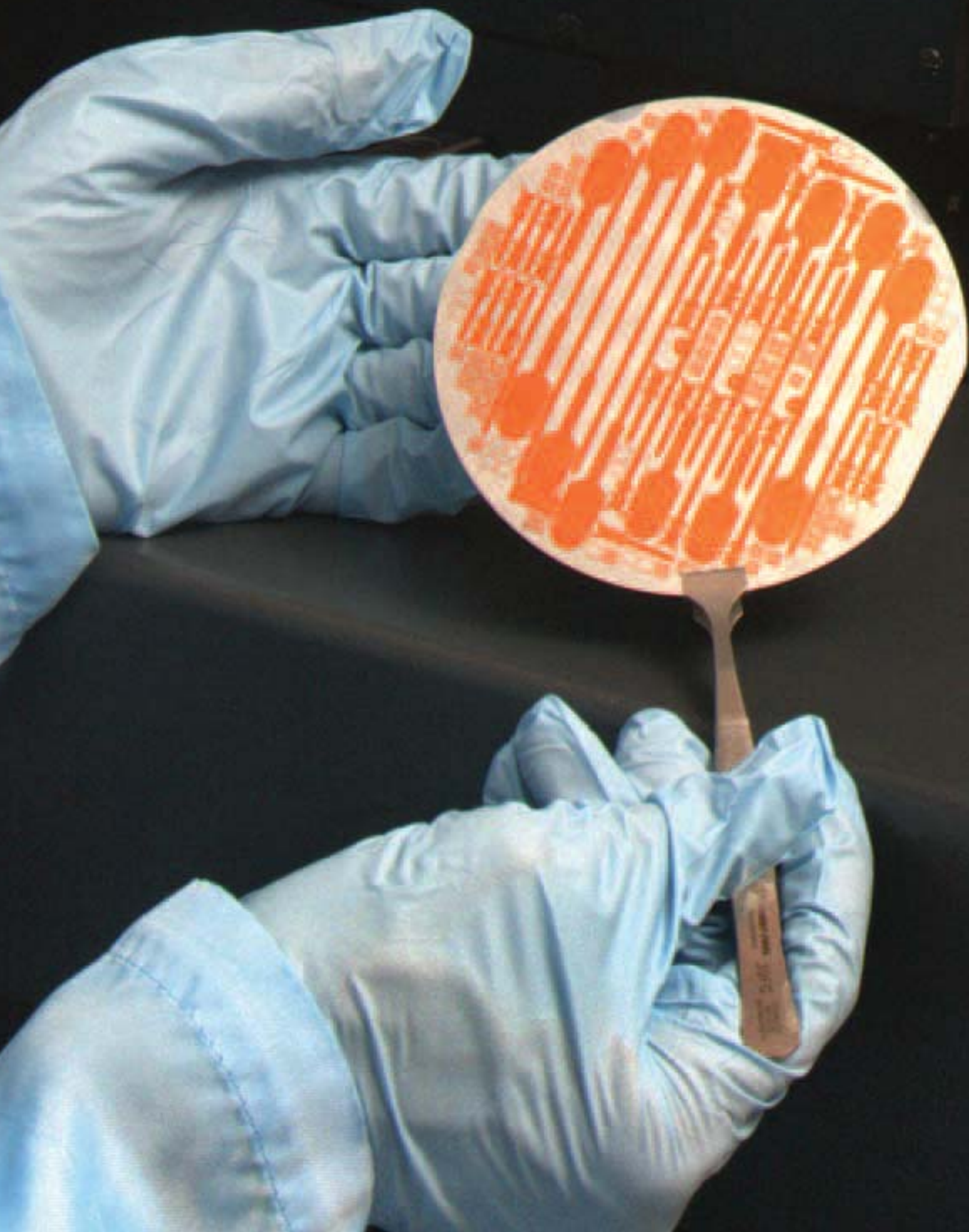

Small Business Impact

Small businesses are critical to the commercialization of nanotechnology. Ideas for new nanotechnology products are being generated rapidly, both within academia and industry. Simultaneously, significant venture capital resources have been made available to commercialize these nanotechnology ideas into useful products for the consumer, industrial, and military sectors.

While ideas and capital are readily available, small businesses are often short of two critical resources: appropriate infrastructure resources and time. Even if money is available, they often do not have the time or the manpower to develop new facilities (laboratories and cleanrooms) or to specify, buy, and install sophisticated equipment, particularly until they have a proven product.

Facilities like NNIN are thus crucial to the success of these new ventures. Through NNIN, a small company can have almost immediate access to state-of-the-art facilities and technology covering almost all areas of nanotechnology. Hundreds of start-up companies are dependent upon NNIN for their initial research and product development.

The following pages highlight the achievements of a few of the hundreds of small businesses which have used NNIN facilities.

Intellectual property

Intellectual property and its protection are critical to most industrial as well as many academic researchers. No company can afford to trade its IP for access to facilities. This is one reason that collaboration is an ineffective model for interaction between academia and industry. The time required to negotiate a suitable intellectual property agreement is too slow for the fast pace at which nanotechnology progresses.

NNIN lab use is not based on collaboration, however. Our facilities are open user facilities, allowing our users to keep their intellectual property to themselves. Our staff are available to help and instruct but generally will not directly participate intellectually unless by special arrangement. Similarly, our institutions make no claim upon intellectual property based solely on use of our facilities. As such, a user's intellectual property remains his, unadulterated by interaction with NNIN staff or students. Only a simple liability agreement is required to gain access, allowing NNIN to respond agilely to new-user inquiries. This mode of interaction has proven to be very successful.

This simple IP protection mechanism (don't ask, don't tell) serves both the small company users and the NNIN facilities well and is critical to the vitality of the facilities.

Small Business Impact

BinOptics Corporation

Integrated Optoelectronics

BinOptics Corporation, located in Ithaca, N.Y., manufactures monolithically integrated optoelectronic components based on indium phosphide and other semiconductor materials. BinOptics' current products include edge-emitting and surface-emitting Fabry Perot lasers, DFB lasers, and lasers with integrated monitoring photodiodes that provide transceiver and transponder manufacturers with unprecedented price-performance advantages

BinOptics' etched-facet laser technology is built upon technology developed in the Cornell facility in the 1990s. Started in 2000 and funded by several prominent Silicon Valley venture capital firms, BinOptics has made heavy use of facilities at the Cornell NanoScale Facility, while recently establishing sufficient capability of its own to support its manufacturing and development processes.

Most recently, BinOptics became the first manufacturer to produce a short-cavity, GaN-based, continuous-wave blue laser using etched-facet technology instead of the mechanical cleaving method currently used by the industry.

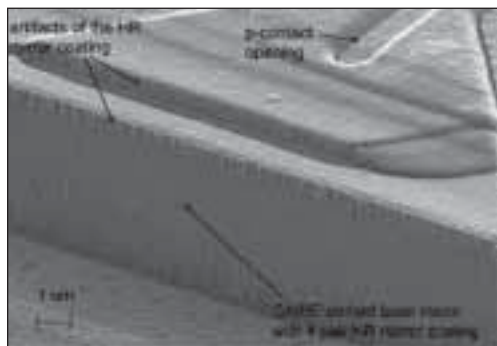

Etched facet laser

OrganicID

New Technology for RFID Devices

OrganicID is a developer of printed radio frequency identification (RFID) and a holder of proprietary technology to design and develop low-cost, item-level RFID tags.

At the MRC-UT Austin, OrganicID developed organic semiconductors with performance sufficient to develop low-cost circuits for RF/ID applications. The OrganicID devices are based on a low-cost organic electronic process technology that enables the production and commercialization of printable electronic RF/ID tags for bar-code replacement.



This is accomplished with tailored printing presses using various electronic inks and innovative design concepts.

In April 2005 at a Materials Research Society Meeting, OrganicID announced the world's First successful 13.56MHz organic circuit.

In October 2006, OrganicID became part of Weyerhaeuser Inc. While they are building their own cleanroom facilities at Colorado Springs, OrganicID continues to use the MRC facility for development activities.

OrganicID (www.organicID.com) currently employs ten people.

TRS Technologies, Inc.

Piezoelectric Devices

TRS Technologies, a small business located in State College, Pennsylvania, specializes in development, prototyping, and manufacturing of advanced piezoelectric and dielectric materials and components for medical, military, and industrial applications. TRS is currently producing and developing high-quality piezoelectric ceramics, precision-machined ceramic components, medical ultrasound transducers, Navy sonar transducers, high-energy capacitors, and severe environment capacitors.

TRS has used the Penn State Nanofabrication Facility to develop a high-frequency ultrasound transducer for intravascular ultrasound (IVUS), which is used to characterize plaque in blood vessels and to aid in the placement of cardiac stents. The technology developed at the Penn State Nanofab enabled a dramatic increase in image resolution, providing clearer images to better identify at-risk plaques and to improve the accuracy of stent placement. TRS has licensed this technology to a Fortune 500 medical-device company which plans on releasing the transducer in its IVUS catheters in 2009.

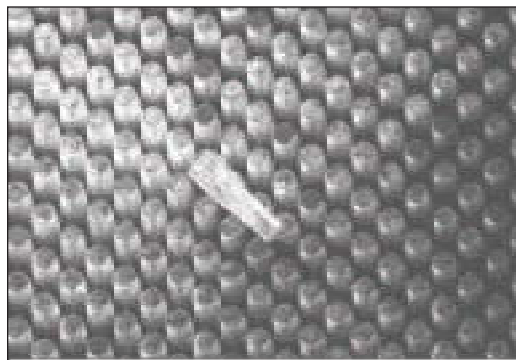

Micromachined piezoelectric single crystal for high-frequency intravascular ultrasound

TRS made use of laser-writing photolithography and a deep reactive ion etching system at the Penn State Nanofab to form very deep trenches ($> 60 \mu\text{m}$) in a complex oxide piezoelectric crystal. Penn State is one of the few nanofabrication facilities in the world with the capability needed to perform this work.

With 36 employees and a current revenue of only \$5M per year, affordable access to state-of-the-art facilities such as those at the Penn State facility is critical to continued development and expansion of their business.

“TRS would not have been able to develop micromachined ultrasound transducers without access to the facilities and specialized equipment at the Penn State Nanofab. The expertise of the staff at Penn State in processing exotic materials enabled the early success needed in the project to attract the interest of the medical-device community. The fact that the Nanofab is a user facility allowed TRS personnel to develop proprietary processes for a specific product and to protect the resulting intellectual property. Because of the Penn State Nanofab and the NNIN, TRS was able to develop a highly innovative new technology that will allow our company to grow, create jobs in our region, and improve public health.”

**— Wes Hackenberger, President,
TRS Technologies, Inc.**

Small Business Impact

CardioMEMS

Wireless Medical Sensing Devices and Systems

CardioMEMS is a medical-device company that has developed and is commercializing a proprietary wireless sensing and communication technology for the human body. Its technology platform is designed to improve the management of severe chronic cardiovascular diseases such as heart failure and aneurysms. Miniature wireless sensors can be implanted using minimally invasive techniques and transmit cardiac output, blood pressure, and heart rate data that are critical to the management of patients. Due to their small size, durability, and lack of wires and batteries, these sensors are designed to be permanently implanted into the cardiovascular system, using radiofrequency to transmit real-time data to an external electronics module.

CardioMEMS's first commercial device, the EndoSure® Wireless AAA Pressure Measurement System, is comprised of an implanted sensor and an external electronics module. More than 2,000 patients have been treated with the EndoSure® system to date.

CardioMEMS, a user of the Georgia Tech MiRC since they were founded in 2000, currently employs 120 people, 11 of whom use the Georgia Tech facility.

Claro Chemical Corporation

Nanoparticles for Paint and Coatings

Claro Chemical Corporation, a start-up company located in Atlanta, Georgia, specializes in the introduction of nanotechnology products into the chemical industry. While initially seeking the help of the Georgia Tech facility for characterization of silver nanoparticles supplied by a third party, it soon sought to develop its own process for the fabrication of these particles. Aided by Georgia Tech staff, Claro was able to document a process for consistently producing nanometer silver particles at 2 to 40 nm sizes for use in paint and coatings applications. With NNIN staff support, Claro was able to produce a product that not only can be used in paint and coatings applications but also provide opportunities in other markets. Claro Chemical has had three employees using the Georgia Tech facility.

Evigia Systems, Inc.

Wireless Sensor Systems

Evigia, located in Ann Arbor, Michigan, specializes in the development and commercialization of highly integrated, low-power, high-performance, sensing systems. By integrating various types of sensors onto integrated circuits, Evigia uniquely provides increasingly functional yet low-cost RFID and wireless sensor tags that are transforming the RFID marketplace. An example of a target application is to make RFID units that can be placed in a shipping container with pharmaceuticals that spoil if not kept refrigerated.

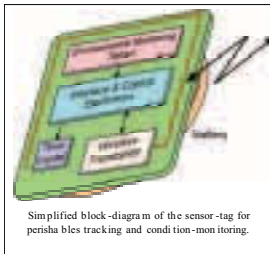

Simplified block-diagram of the sensor-tag for perishables tracking and condition-monitoring.

Typically, multi-sensor systems have been formed by assembling many discrete sensors and circuit components. Evigia is integrating wireless RF, MEMS sensors, logic circuitry, and other components onto a highly

functional yet low-cost active RFID platform. Evigia's core technology is on post-CMOS proprietary integration of MEMS/NEMS sensors and circuits and packaging at wafer-level, and ultra-low-power circuits and sensors.

As a fabless company, Evigia performs its technology R&D and prototype development at the Michigan Nanofabrication Facility (MNF), using the full range of silicon processing and MEMS technologies available there. These newly developed fabrication processes will be transferred to commercial foundries for production.

Founded in 2004, Evigia has grown from three employees in 2006 to eight full-time and six part-time employees in 2007.

EMAG Technologies

Fabrication of RF Phased Antenna Arrays

Since 1994, EMAG Technologies has been providing RF design solutions and services to the government and industry. Integrated RF front ends are the cornerstone of the next generation of wireless and satellite communication systems, radars and intelligent sensors. The ability to transmit and receive vast amounts of information from ground, satellite, mobile, or airborne platforms to large numbers of users requires revolutionary concepts in antenna design, circuit implementation and fabrication techniques to achieve what is considered by today's standards the ultimate performance, smallest size, and minimal cost. EMAG Technologies Inc. started as an R&D company to bridge the gap between advanced research and reliable product development in the RF industry. The company has since grown and transitioned a number of novel concepts successfully into commercial products.

EMAG Technologies offers a variety of services, including custom RF, millimeter and microwave circuit design, fabrication of silicon and GaAs micromachined RF components, test and measurement, and design and prototyping of RF systems for various communications and sensing applications. Fabrication of components is done at the Michigan Nanofabrication Facility. EMAG, located in Ann Arbor, Michigan, has been using the MNF since October 2005 and currently has two engineers working on device development and fabrication in the MNF.



Silicon posts for transitioning a coplanar waveguide ground plane between two wafers (Posts are approximately 1 μ m square in area.)

Small Business Impact

SiTime Corporation

Silicon MEMS-based Timing Devices

Although stand-alone MEMS devices are now commonplace, environmental requirements for operation and processing constraints of MEMS devices have traditionally prevented full integration with advanced electronics. SiTime develops and markets chips incorporating MEMS-based reference timing devices within standard silicon chips, which eliminate the need for quartz microcrystals. The result is the world's smallest, fully integrated, fully packaged resonators and oscillators, which can be used in hand-helds, wireless, and other miniaturized communications devices.

The technology that made SiTime possible arose out of an academic research collaboration between the Bosch Corporation Research and Technology Center and Professor Thomas Kenny of the Stanford University Department of Mechanical Engineering, which was funded through DARPA and largely done at SNF. As the technology became more developed, wafers were shuttled between Bosch and SNF at appropriate process points. Later, the process was transferred to a foundry so that SiTime is now a fabless company shipping 300,000 parts per week.

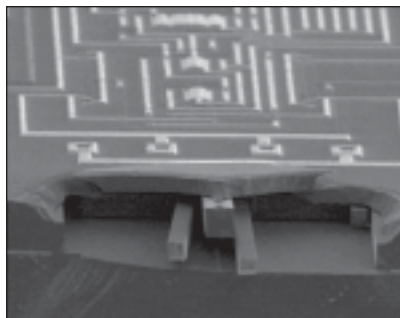

Single crystal Si encapsulation layer allows CMOS integration.

TelAztec

Antireflective Surface Structures

TelAztec is currently developing radiation hard antireflective surface structures for space-based applications. Antireflection surface structures have been designed and fabricated in CdZnTe substrates for backside illuminated HgCdTe LWIR detectors.

These structures replace traditional thin film AR coatings and eliminate problems such as limited performance, delamination, stress, poor off-axis performance, and susceptibility to radiation damage. Reactive ion etching at the University of California, Santa Barbara nanofabrication facility has aided in development of AR microstructures in several infrared transmitting materials, including CdZnTe, ZnSe, Ge, sapphire, and silicon.

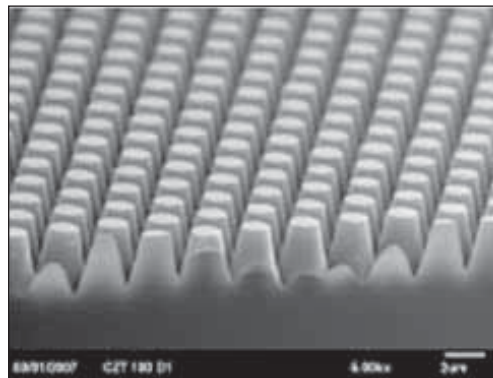

Motheye Graded Index Antireflection Structure etched into CdZnTe substrate for radiation hard LWIR applications



NNIN Funding

Base funding for NNIN is provided by the National Science Foundation through a cooperative agreement that provides a total of \$14 million annually. This is provided in the form of a five-year agreement initiated in 2004 and with a second five-year agreement to be negotiated in 2009 upon review. This long-term base funding is critical for the NNIN facilities to provide the necessary stability to establish and maintain our programs.

NSF/NNIN funds are divided among the 12 NNIN sites, in amounts ranging from \$2.5 million to \$500,000, depending upon site size, number of users, and the amount of technology

offered. All this funding is to support facilities, not to directly support research. To a large extent, the NSF funds pay the (relatively) fixed staff costs of operating the facilities and supporting the user community.



While this base government funding is critical, it is by no means sufficient to establish or sustain operation. All users of NNIN facilities pay user fees. Collectively these fees provide \$16 million in additional operating funds across the network. In addition, some sites may have additional university, state, or industrial funding for facility operations. To a large extent, user fees go to pay the variable operation costs of the facilities — maintenance and expendables.

None of these funds pay for the cost of buildings, which are an expense borne by the universities directly. In the last five years, three NNIN sites have moved into completely new facilities; a fourth is under construction. Collectively these represent an investment of almost \$500 million by the universities within NNIN.

None of this addresses the very major issue of capital equipment. Nanotechnology equipment is expensive and the state-of-the-art equipment that is required to support advanced research by the user community rapidly depreciates in usability and value. While some items can remain effective for 10, 15 or even 20 years, the most sophisticated instruments must be replaced on a five-year time table. With well over \$300 million in capital equipment resources (lithography, etching, characterization, computation, etc.) across the network, capital equipment acquisition and replacement is a major obstacle to the operation of state-of-the-art shared network facilities. Even with very conservative 10-year replacement schedule, \$30 million in capital equipment must be acquired or replaced each year. This dwarfs all available sources of real cash available. For example, at most, \$1 million out of the base NNIN funding is available, with possibly a similar amount available from user fees. Obviously, there are other ways NNIN sites also receive some funds (< \$1 million per year) for equipment through equipment competitions such as the NSF Major Research Instrumentation program, either sought by NNIN directly or by individual sites acting upon their own. Similarly, the funded research centers that enjoy a symbiotic relationship with the NNIN sites sometimes provide specialized equipment that is critical to their programs.

In the end, however, these sources combined are not adequate to maintain the capital assets of the network. Our facilities must rely heavily upon donations from our industrial partners which have a vested interest in nanotechnology, either in the research output of the network or in our students.

In many cases, NNIN sites can be receptive to the donation of used equipment. The NNIN office can help facilitate this opportunity. Increasingly, however, production fabrication tools are not well suited for the size of a university laboratory environment.

Vital parts of the NNIN strategy for serving users

Leverage and Critical Mass

Leverage

NNIN provides significant leverage in support of the national research agenda. Supported by only 125 full time equivalent staff, each year more than 4,400 researchers depend on NNIN for at least part of their research and development activity. Almost 4,000 of these are students; NNIN is responsible for over 500 Ph.D.s in nanotechnology each year. Even conservatively estimated, this activity translates to over \$500 million of research annually within the academic community alone, providing extremely high leverage to the \$14 million direct government

investment in NNIN annually. Similarly, with more than 350 companies each year dependent upon its resources, NNIN has a significant economic impact as well.

Critical Mass

There are now literally hundreds of advanced nanotechnology and microtechnology laboratories at major universities across the country. And yet NNIN remains uniquely successful, and in fact counts users from many of those institutions within its user base.

The fixed costs of operating these facilities are huge and can only be supported if there is significant income from

usage. And the instruments are only maximally useful if there are adequate users to keep them fully characterized. Very few institutions have an

adequately large research base to support the equipment base that is necessary to operate a broadbased state-of-the-art nanotechnology facility. While grants such as our NSF support are necessary, they are not sufficient to support the entire operation. Our facilities require a critical mass of users to operate — and because of the large technology base and high visibility of NNIN, we are able to attract this critical mass.

Given the level of funding for research projects, the only stable operating point for facilities such as the NNIN sites is to have a large number of users, each paying a small fraction of the total operating cost. This is the model that NNIN facilities have adopted and successfully employed.

Usage and Availability

NNIN facilities enjoy both high uptime and a high level of use. The critical mass of users makes it possible to adequately maintain the equipment, either through service contracts or dedicated staff. As a result, many NNIN instruments enjoy more than 90 percent uptime, a level unheard of in other academic laboratories. Similarly, many tools in NNIN laboratories are used more than 100 hours per week, often by 10 or more individuals per day. This is in stark contrast to many smaller university research facilities. High levels of usage and availability are mutually dependent upon each other, as high usage can only be obtained with high availability, and high availability requires high usage to support the necessary maintenance costs. NNIN shared facilities and their associated large user base are thus uniquely effective in providing nanotechnology resources on an open basis.

User Fees

All NNIN users pay fees to help offset the cost of operation. Fees are kept as affordable as possible to encourage exploratory use. Each site has its own algorithm for assessing fees, but they are generally assessed on a per-use or per-hour basis. There are no up-front membership fees.

For academic users, many fees are in the \$20 per-hour range; even a very heavy user would incur fees less than \$20,000 per year. The average academic user pays on average \$2,000 per year. Fees for industrial use are generally higher, but again even a very heavy user is unlikely to accumulate more than \$75,000 per year in fees. Most users pay a mere fraction of that. All of these pale in comparison to the salary costs of a professional employee or to the costs of providing even a rudimentary laboratory facility. On the other hand, costs significantly higher would preclude much of the exploratory research that makes NNIN facilities vibrant.

Advisory Board

In the development of its long-term strategy, NNIN enjoys the counsel of an independent advisory board. The NNIN Advisory Board includes eminent scientists, engineers, and administrators from academia, government and industry, representing a cross-section of the nanotechnology fields served by NNIN. These are individuals with stature, experience, and independence who can help the network evolve through critical advice and guidance of programs, activities, vision, and future directions. Some of these individuals have advised NNIN (and its predecessor NNUN) for more than 10 years. NNIN is fortunate to have their dedicated service and takes their recommendations seriously.

The NNIN Advisory Board strongly supports the role played by NNIN within the national nanotechnology community. However, board members have been concerned about sustainability of the business model in light of the enormous capital expense involved in maintaining state-of-the-art facilities. With their counsel, NNIN is seeking to broaden its base of financial support so that it can continue to facilitate nanotechnology research well into the 21st century.

NNIN Advisory Board

Dr. Samuel Bader

Associate Division Director
Materials Science Division
Argonne National Laboratory

Dr. William Brinkman

Senior Physicist, Princeton University
Retired VP, Research, AT&T Bell Labs

Sir Harold Kroto

Department of Chemistry
Florida State University

Dr. Carl Kukkonen

CEO
ViaSpace Technologies

Prof. George Langford

Dean of Natural Sciences and Mathematics
University of Massachusetts

Dr. Jim McGroddy

Retired Senior VP, Research
IBM

Prof. Hans Mooij

Chairman
Kavli Institute of Nanoscience
Delft University of Technology

Prof. Paul Peercy

Dean of Engineering
University of Wisconsin

Dr. Kurt Petersen

CEO & Chairman
SiTime

Dr. Tom Theis

Director of Physical Sciences
IBM Research

Prof. Karen Wooley

Professor of Chemistry
Washington University, St. Louis

To contact the NNIN directly, please call or write to:

National Nanotechnology Infrastructure Network (NNIN) c/o CNF
250 Duffield Hall
Cornell University
Ithaca, New York 14853
(607) 255-2329



The National Nanotechnology Infrastructure Network is funded by the National Science Foundation, under master Cooperative Agreement ECS-0335765 with Cornell University, which subcontracts to other NNIN sites. Supplementary funding at each site comes from user fees, the universities, and other sources.